

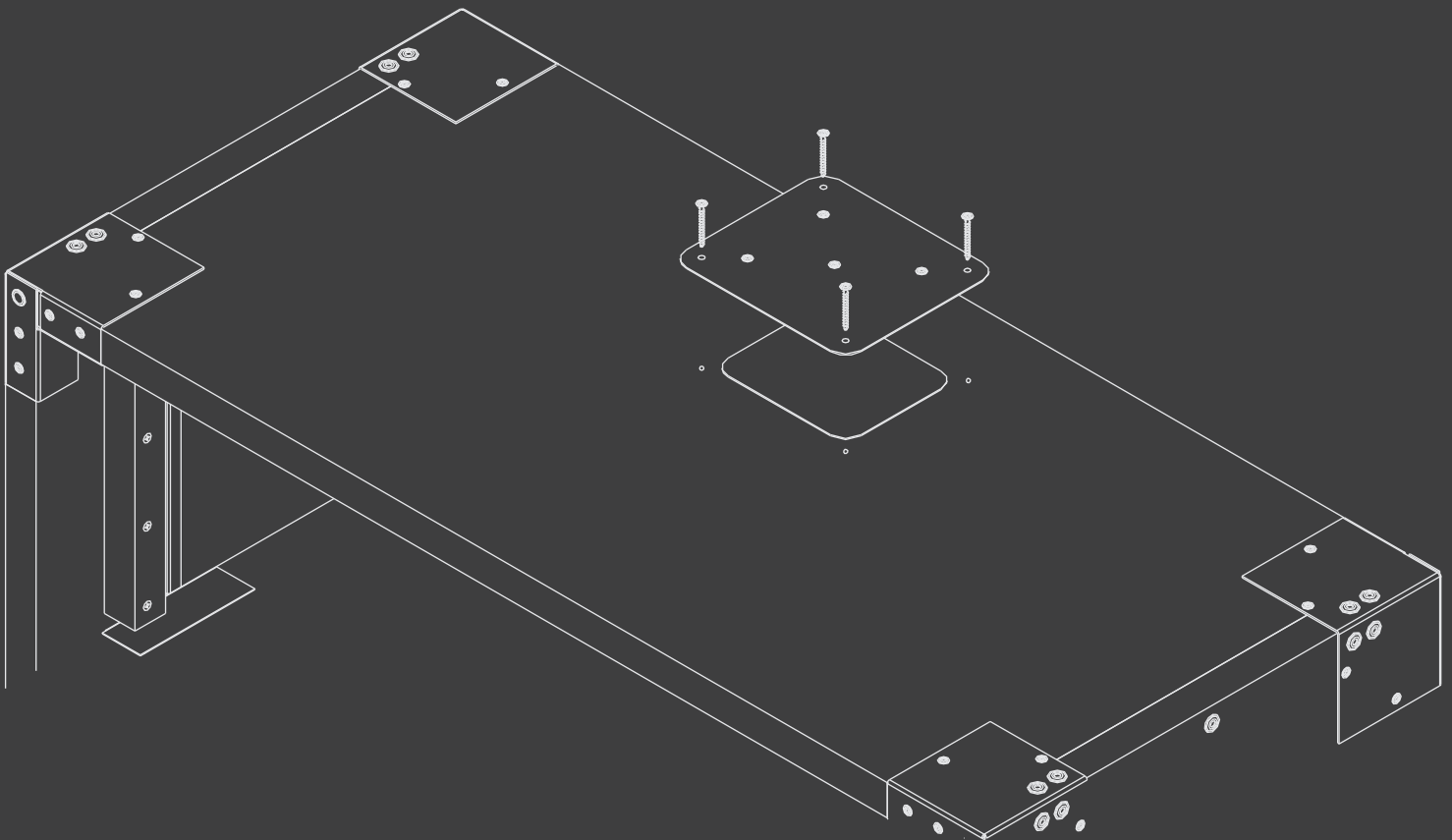

OPERATION & MAINTENANCE MANUAL

FIRE DAMPER, TYPE: FID B



SAFEVENT ApS

Mads Clausens Vej 6
DK-9800 Hjoerring
Denmark

TEL: +45 88 63 89 00
MAIL: sales@safevent.dk
URL: www.safevent.dk/en

TABLE OF CONTENT

1. INTRODUCTION	3
2. SUBJECT	3
3. DEVICE INTENDED USE	3
3.1 APPLICATION	3
3.2 FIRE RESISTANCE	3
3.3 EXECUTION VERSIONS	3
3.4 DIMENSION TYPE SERIES	4
4. DESIGN AND OPERATING PRINCIPLE	4
4.1 DESIGN	4
4.2 FUNCTION	4
4.3 TRIGGER CONTROL GEARS	5
4.4 BASIC DIMENSIONS	6
5. DEVICE IDENTIFICATION	6
6. DEVICE ASSEMBLY	6
6.1 PRE-ASSEMBLY INSPECTION	7
6.2 INSTALLATION OPENING	7
6.3 EMBEDDING / FIXING THE DAMPER	7
6.3.01 INSTALLATION OF DAMPER IN PANEL WALLS	8
6.3.02 INSTALLATION OF DAMPER IN SOLID WALLS	8
6.3.03 INSTALLATION OF DAMPER IN RIGID FLOOR – ABOVE THE RIGID FLOOR	9
6.3.04 INSTALLATION OF DAMPER IN RIGID FLOOR – BELOW THE RIGID FLOOR	9
6.3.05 INSTALLATION OF THE DAMPER ON HORIZONTAL DUCTS	9
6.3.06 INSTALLATION OF THE DAMPER ON VERTICAL DUCTS	10
6.3.07 INSTALLATION OF THE DAMPER ON VERTICAL DUCTS 2	10
6.3.08 CONNECTION OF A MULTI-ZONE FIREPROOF DUCT, E.G. MADE OF FIRE RATED BOARDS	11
6.3.09 CONNECTION OF A SINGLE COMPARTMENT FIREPROOF DUCT, E.G. MADE OF METAL SHEETS	11
6.3.10 INSPECTION ACCESS	12
6.3.11 RB CONNECTION SUBFRAME	12
6.3.12 MWB SYSTEM GRILLE	13
6.3.13 INTRODUCTION OF ELECTRIC CABLES FOR ELECTRIC POWER SUPPLY OF THE ACTUATOR	14
6.4 ACTUATORS	14
6.4.01 TYPES OF ELECTRIC ACTUATORS	14
6.4.02 TECHNICAL SPECIFICATIONS OF ELECTRICAL ACTUATORS	14
6.6.01 CONNECTION DIAGRAMS OF ELECTRICAL ACTUATORS	17
6.7 RST/KW1 TRIGGER CONTROL GEAR	19
6.8 INDEPENDENT LIMIT SWITCHES – RST VERSION	21
6.8.01 TECHNICAL SPECIFICATIONS OF THE WK1 AND WK2 LIMIT SWITCHES	21
6.8.02 ELECTRICAL CONNECTIONS DIAGRAM OF WK1 AND WK2 LIMIT SWITCHES	21
7. TRANSPORT AND STORAGE CONDITIONS	21
8. MAINTENANCE AND SERVICING	21
9. WARRANTY TERMS AND CONDITIONS	22

CAUTION!

The product should be stored and used in rooms where:

- there is no access to dust, gases, caustic vapors and other aggressive chemical vapors that can destroy the insulating elements and structural elements;
- the flaps are not affected by direct sunlight and UV radiation;
- the maximum relative humidity does not exceed 80% at the temperature of +20 °C;
- the ambient temperature is between - 20 °C and + 40 °C;
- there are no vibrations.



In the case of cut-off and transfer fire dampers, the device is equipped with a thermal release containing one-time temperature fuses. During normal operation, the above-mentioned element should be protected against the affect of the permissible temperature Tmax (see the table below). When it is exceeded, the temperature fuses may operate, which is a normal operation and is not covered by the guarantee or warranty.

A thermal release for a damper equipped with an electric actuator:

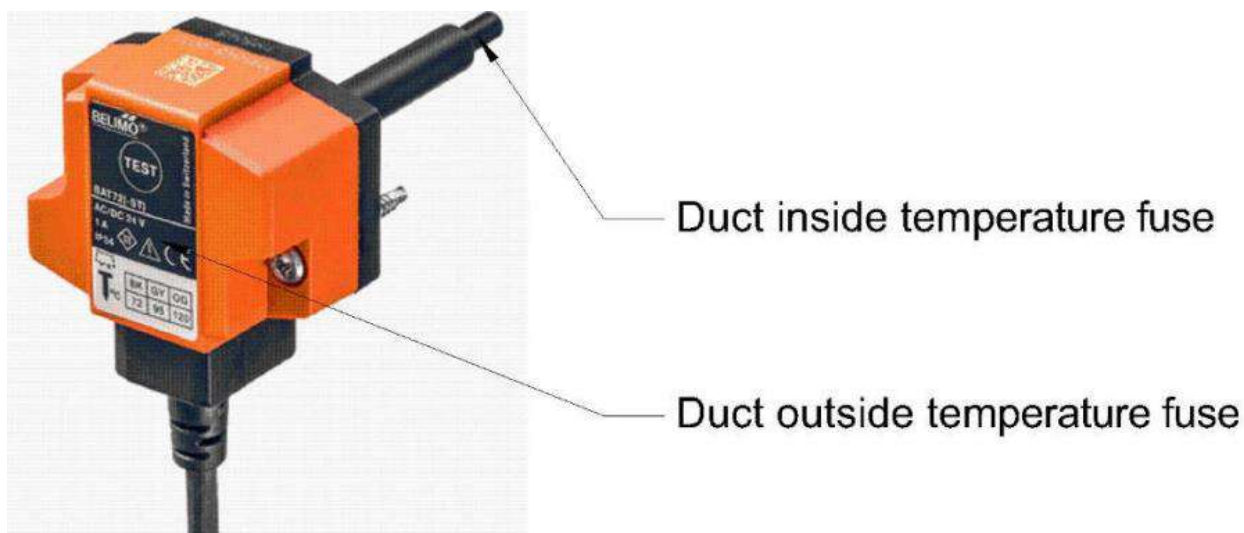

Thermal fuse for temperature	72 °C	95 °C
Temperature fuse inside the duct	Tmax 40 °C	Tmax 60 °C
Outdoor temperature fuse	Tmax 40 °C	Tmax 40 °C

A thermal release for a damper equipped with KW1 or RST mechanism:

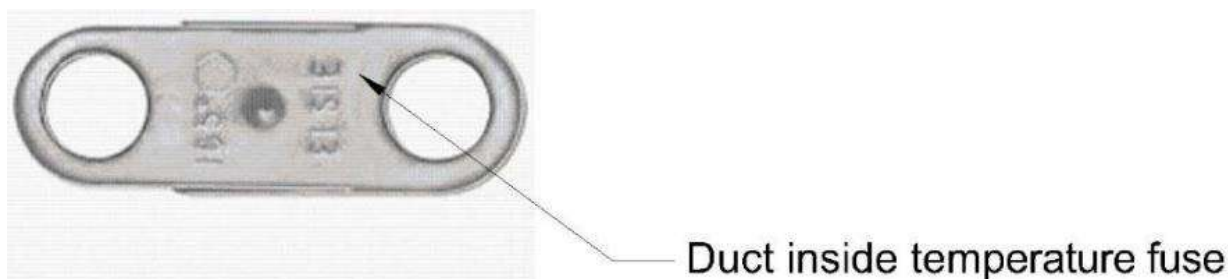

Thermal fuse for temperature	72 °C	95 °C
Temperature fuse inside the duct	Tmax 40 °C	Tmax 60 °C

1. INTRODUCTION

The purpose of this operation and maintenance manual is to get the user acquainted with the intended use, design, the principle of operation, correct installation, and operation of the product. The manual also includes additional information about the operating conditions, maintenance, and warranty conditions of the product.

2. SUBJECT

This manual concerns the entire group of single-plane fire dampers type, FID B. Compliance with the Manual guidelines ensures correct functioning of the device in terms of fire protection of rooms as well as safety of the system users.

3. DEVICE INTENDED USE

3.1 APPLICATION

Single-plane fire dampers type FID B (square cross-section) may be used as:

- ⊗ cut-off fire dampers – FID B/S
- ⊙ cut-off fire dampers for fire ventilation systems – FID B/V
- ⊙ cut-off fire dampers for mixed fire ventilation systems – FID B/M
- ⊗ transfer dampers – FID B/T
- ⊗ relief dampers – FID B/G

CAUTION!

Cut-off fire dampers for fire ventilation systems the FID B/V and fire dampers for mixed fire ventilation systems the FID B/M, have one declaration of performance in accordance with the requirements of law.

The marker -M and the word "mixed" used in the document are trademarks used by the manufacturer.

The construction and execution of the above dampers is the same regardless of the commercial mark.

The FID B dampers have the MA feature (manual activate). This means that the damper partition can change its position during a fire (the damper can open or close). The damper can be operated without deteriorating its fire properties for 25 minutes.

Dampers classified as "MA" can be used wherever a multi-stage fire scenario is required, wherever manual control of the smoke exhaust system by authorized units is allowed during a fire (e.g., the need to "manually" change the position of the damper partitions and "overrides" of the smoke exhaust system automatically started in the wrong fire zone).

The dampers cannot be operated in systems exposed to dust, except for when they are included in a special, individually developed programme of service and technical inspections.

3.2 FIRE RESISTANCE

⊗ EL60S	⊗ /S	⊗ /V	⊗ /V-M	⊗ /T	⊗ /G	⊙ E1120S	⊗ /S	⊙ /V	⊙ /V-M	⊗ /T	⊗ /G
⊗ EL60	⊗ /S	⊗ /V	⊗ /V-M	⊗ /T	⊗ /G	⊙ E1120	⊗ /S	⊙ /V	⊙ /V-M	⊗ /T	⊗ /G
⊗ E60S	⊗ /S	⊗ /V	⊗ /V-M	⊗ /T	⊗ /G	⊙ E120S	⊗ /S	⊙ /V	⊙ /V-M	⊗ /T	⊗ /G
⊗ E60	⊗ /S	⊗ /V	⊗ /V-M	⊗ /T	⊗ /G	⊙ E120	⊗ /S	⊙ /V	⊙ /V-M	⊗ /T	⊗ /G

3.3 EXECUTION VERSIONS

FID B dampers can be made as rectangular dampers.

3.4 DIMENSION TYPE SERIES

FID B fire dampers are manufactured in the following size ranges:

- Width: 200 to 1200 mm
- Height: 200 to 800 mm
- Width: 600 mm

Aside from the standard dimensions, the fire dampers may also be manufactured in intermediate sizes. The damper casing can be made longer on request. Maximum surface area of type FID B dampers: 0,96 m². The minimum damper surface area is 0,04 m².

4. DESIGN AND OPERATING PRINCIPLE

4.1 DESIGN

The FID B dampers consist of a casing with a rectangular cross-section consisting of fireproof boards, a movable cut-off partition and an actuator operated manually or remotely. The cut off partition of the dampers is made of fireproof boards and is set in a sheet-metal profile. There is a ventilation gasket on the inside of the housing. Retaining sections made of fireproof boards are attached to the inner surface of the housing, limiting the movement of the rotating partition. The sections are covered with a ventilation gasket. Corners made of steel, galvanized or stainless steel are attached to the outer surface of the housing in the corners. For chemically aggressive environments, special enclosures are used, where the fireproof boards are impregnated.

4.2 FUNCTION

The operating principle and behaviour of the FID B single-plane dampers depend on their application versions:

- ⊗ **cut-off fire dampers –FID B/S**
In the normal operating position, the dampers are open. The dampers are closed (to the safety position) as follows:
 - ⊗ automatically, by tripping the thermoelectric trigger
 - ⊗ remotely, by tripping an electric axial actuator with a return spring caused by isolation from the supply voltage
 - ⊗ automatically, by tripping the thermal trigger and the driving spring
- ⊙ **cut-off fire dampers for fire ventilation systems – FID B/V**
In the normal operating position, the dampers are open or closed depending on the function. The dampers are closed/opened as follows:
 - ⊙ remotely, by tripping an electric axial actuator without a return spring, as a result of applying the supply voltage to the actuator in the right manner. The damper blade can change position without loss of device functionality for 25 minutes from the time of activation of operation.
 - ⊗ remotely, by tripping the electromagnetic release and a spring as a result of applying the voltage
- ⊗ **cut-off fire dampers for mixed fire ventilation systems – FID B/M**
In the normal operating position, the dampers are open or close depending on the function. The dampers are closed/opened as follows:
 - ⊙ remotely, by tripping an electric axial actuator without a return spring, as a result of applying the supply voltage to the actuator in the right manner. The damper blade can change position without loss of device functionality for 25 minutes from the time of activation of operation.
 - ⊗ remotely, by tripping the electromagnetic release and a spring as a result of applying the voltage

- ⊗ **transfer fire dampers - FID B/T**
In the normal operating position, the dampers are open or closed. The dampers are switched to the safety position as follows:
 - ⊗ automatically, by tripping the thermoelectric trigger
 - ⊗ manually, by pressing the control button on the thermoelectric trigger
 - ⊗ remotely, by tripping an electric axial actuator with a return spring caused by isolation from the supply voltage
 - ⊗ automatically, by tripping the thermal trigger and the driving spring

- ⊗ **relief fire dampers - FID B/G**
In the normal operating position, the dampers are open or closed. The dampers are switched to the safety position as follows:
 - ⊗ automatically, by tripping the thermoelectric trigger
 - ⊗ manually, by pressing the control button on the thermoelectric trigger

It is possible to manually service check the proper performance of the dampers with electrical actuators by placing a special hex wrench in the socket marked on the actuator and rotating it to set the damper isolating partition in the relevant position. Rotate the wrench slowly, smoothly and carefully. Rotating the wrench too fast or too rapidly may damage the internal actuator gear or the drive transmission system. It is possible to manually service check the proper performance of the integrated damper with the trigger control gear by pressing the lever on the gear. The mcr T2 tester is recommended to check the proper performance of dampers with electric actuators.

CAUTION!

Never pull directly on the damper isolation partition to open or close the device. This may result in damage of the self-locking driving gear of the damper that is not covered by warranty. It is recommended that the fire damper is opened and closed when the ventilation system is turned off.

4.3 TRIGGER CONTROL GEARS

The following trigger control gears are available for the FID B fire dampers:

ELECTRIC ACTUATOR:

⊗ BF 230-T	⊗ /S	⊗ /V	⊗ /V-M	⊗ /T	⊗ /G
⊗ BF 24-T (-ST)	⊗ /S	⊗ /V	⊗ /V-M	⊗ /T	⊗ /G
⊗ BF 24-T-TL	⊗ /S	⊗ /V	⊗ /V-M	⊗ /T	⊗ /G
⊗ BFL 230-T	⊗ /S	⊗ /V	⊗ /V-M	⊗ /T	⊗ /G
⊗ BFL 24-T (-ST)	⊗ /S	⊗ /V	⊗ /V-M	⊗ /T	⊗ /G
⊗ BFN 230-T	⊗ /S	⊗ /V	⊗ /V-M	⊗ /T	⊗ /G
⊗ BFN 24-T (-ST)	⊗ /S	⊗ /V	⊗ /V-M	⊗ /T	⊗ /G
⊗ BF 24-TN (-ST)	⊗ /S	⊗ /V	⊗ /V-M	⊗ /T	⊗ /G
✓ BEE 230	⊗ /S	✓ /V	✓ /V-M	⊗ /T	⊗ /G
✓ BEN 230	⊗ /S	✓ /V	✓ /V-M	⊗ /T	⊗ /G
⊗ MF 230-T	⊗ /S	⊗ /V	⊗ /V-M	⊗ /T	⊗ /G
⊗ MLF 230-T	⊗ /S	⊗ /V	⊗ /V-M	⊗ /T	⊗ /G
✓ BE 230	⊗ /S	✓ /V	✓ /V-M	⊗ /T	⊗ /G
✓ BE 24 (-ST)	⊗ /S	✓ /V	✓ /V-M	⊗ /T	⊗ /G
✓ BLE 230	⊗ /S	✓ /V	✓ /V-M	⊗ /T	⊗ /G
✓ BLE 24 (-ST)	⊗ /S	✓ /V	✓ /V-M	⊗ /T	⊗ /G
⊗ EXBF 230	⊗ /S	⊗ /V	⊗ /V-M	⊗ /T	⊗ /G
⊗ EXBF 24	⊗ /S	⊗ /V	⊗ /V-M	⊗ /T	⊗ /G
⊗ BF 230-TN	⊗ /S	⊗ /V	⊗ /V-M	⊗ /T	⊗ /G
⊗ BF 24-TN-TL	⊗ /S	⊗ /V	⊗ /V-M	⊗ /T	⊗ /G
✓ BEE 24 (-ST)	⊗ /S	✓ /V	✓ /V-M	⊗ /T	⊗ /G

✓ BEN 24 (-ST)	✗ /S	✓ /V	✓ /V-M	✗ /T	✗ /G
✗ MF 24-T	✗ /S	✗ /V	✗ /V-M	✗ /T	✗ /G
✗ MLF 24-T	✗ /S	✗ /V	✗ /V-M	✗ /T	✗ /G

SPRING GEAR:

✗ RST	✗ /S	✗ /V	✗ /V-M	✗ /T	✗ /G
✗ RST/KW1/24P	✗ /S	✗ /V	✗ /V-M	✗ /T	✗ /G
✗ RST/KW1/230P	✗ /S	✗ /V	✗ /V-M	✗ /T	✗ /G
✗ RST/KW1/S	✗ /S	✗ /V	✗ /V-M	✗ /T	✗ /G
✗ RST/KW1/24I	✗ /S	✗ /V	✗ /V-M	✗ /T	✗ /G
✗ RST/KW1/230I	✗ /S	✗ /V	✗ /V-M	✗ /T	✗ /G

4.4 BASIC DIMENSIONS

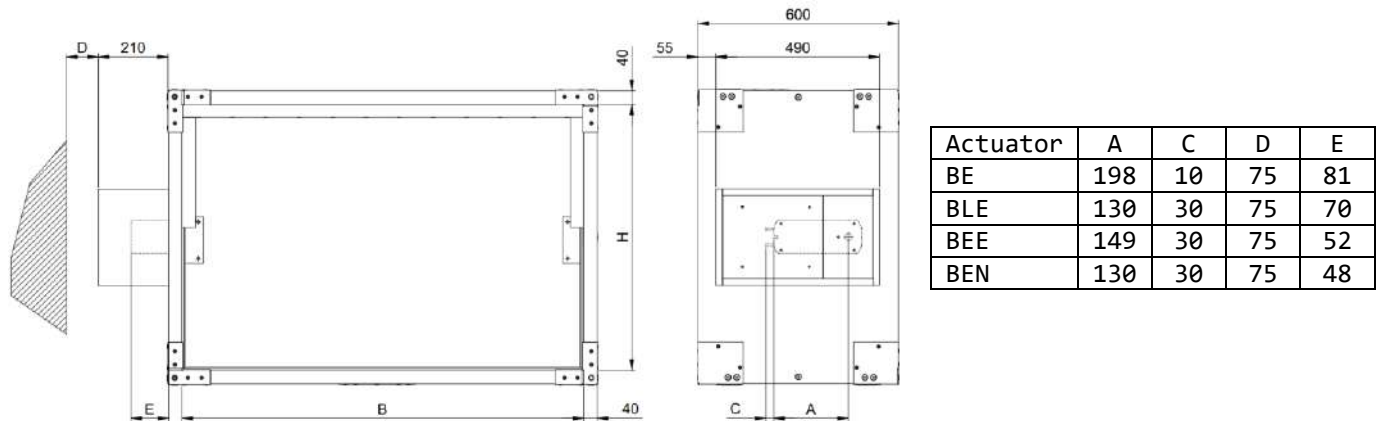

5. DEVICE IDENTIFICATION

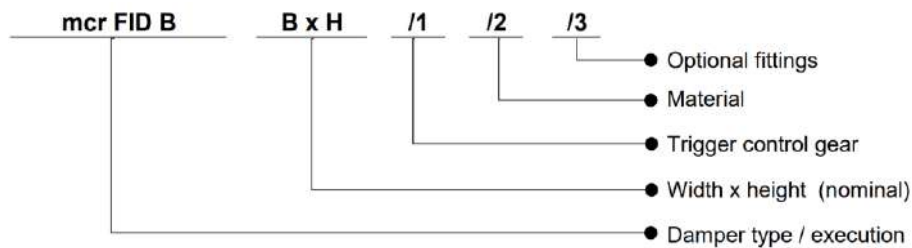

6. DEVICE ASSEMBLY

CAUTION!

During the assembly of the damper and installation finish, future access to the device and removal of the trigger control gear must be considered to enable servicing and inspection.

The FID B dampers can be installed at a distance from the following building partitions:

- ✓ walls with a wooden structure of the thickness required for fire resistance
- ✓ walls made of boards with the thickness required for fire resistance
- ✓ masonry walls of the thickness required for fire resistance
- ✓ masonry walls made of bricks or blocks of the thickness required for fire resistance
- ✓ rigid floor with the thickness required for fire resistance

Additionally, the dampers can be installed:

- ✓ outside the partitions (walls, ceilings)
- ✗ in modules (multiple dampers sets)

6.1 PRE-ASSEMBLY INSPECTION

Each fire damper is factory inspected by the manufacturer prior to packing and shipping. Upon unpacking the delivered fire damper, visually examine it for any damage in transport or casing deformation.

6.2 INSTALLATION OPENING

The minimum size of the opening enabling the correct installation of a rectangular damper is, depending on the thickness of fire-resistant duct system:

- ✔ fire protection duct wall thickness 40mm: X min. 160mm
- ✔ fire protection duct wall thickness 50mm: X min. 200mm
- ✔ fire protection duct wall thickness 60mm: X min. 180mm

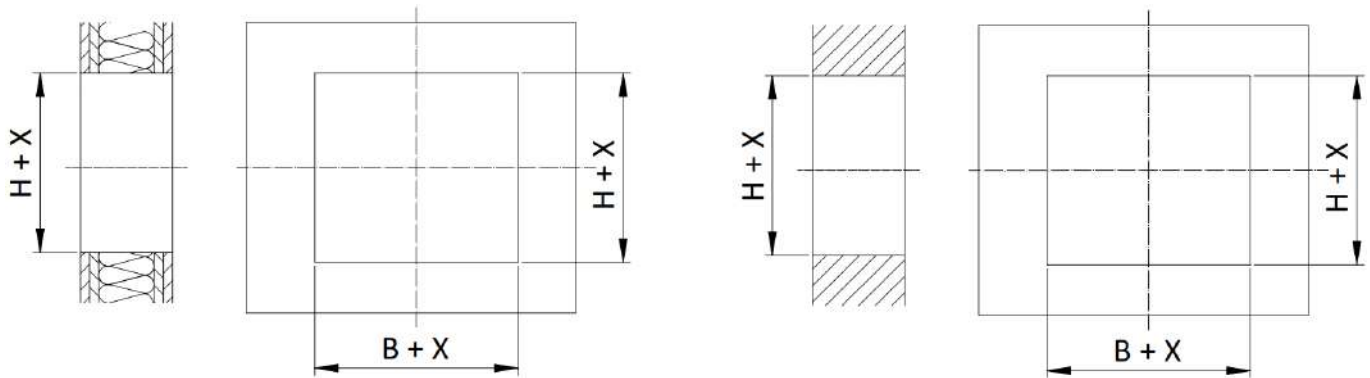

Preparation of the installation opening

6.3 EMBEDDING / FIXING THE DAMPER

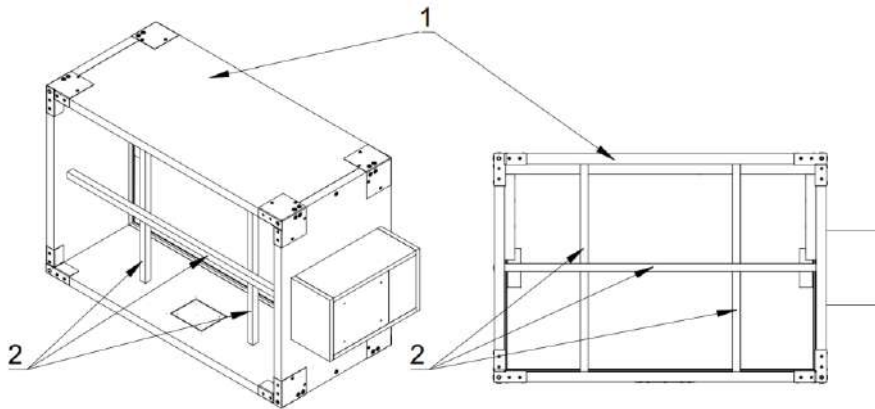

- 1. Damper FID B BxH
- 2. Wooden blocks

The FID B fire damper will work properly if the isolation partition rotation axis is horizontal. If the case of fire damper must have vertical axial, state this when ordering. The trigger control gear may be located on the right or on the left-hand side of the damper at any direction of air flow.

The dampers can be installed on the vertical or horizontal section of the fire ventilation duct across the duct or on the surface of the sides of the duct. The damper can also be installed in a construction shaft used for fire ventilation. Acceptable assembly is shown in the figures further in the document.

Before embedding/fixing, place the damper in the fire ventilation duct or construction shaft used for fire ventilation, please the damper axially in the previous prepared opening. Level the device and secure in place. Next, actuate the damper isolation partition by hand to verify that the rotation is correct (i.e., there is no collision with the damper casing parts, etc.).

Close the damper isolation partition. Install the bracing as shown in the figure. Carefully fill the gap between the damper casing and the duct with a proper mortar formula that ensures proper duct and damper fire resistance, and do not let the mortar get into the damper actuation components (i.e., the trigger control gear, the isolation partition, gaskets and stops). To do this, the fire damper must be covered with plastic film or other suitable material and remain so until the embedding and finishing is done. The damper must remain closed until the mortar has cured. Once the mortar has cured, remove the temporary supports and open and close the fire damper to verify its performance.

The embedded fire damper must be coaxially connected to the ventilation duct. Protect the fire damper casing from damage, and specifically from straining the casing during the installation process. The fire damper cannot bear the load of the ventilation duct or the ventilation system in which it is installed. Drilling the damper enclosure or driving screws, bolts or other elements that pierce through the casing to the inside of the damper is prohibited. A mounting frame RB is used to connect a steel ventilation duct. Once connected to the ventilation ducts, re-verify the fire damper performance. With the installation finished, carefully clean the fire damper and make sure that there is no debris which could influence proper performance of the device.

CAUTION!

It is crucial to keep the device embedding envelope so that the trigger control gear is outside of the wall envelope and easily accessible.

6.3.01 INSTALLATION OF DAMPER IN PANEL WALLS

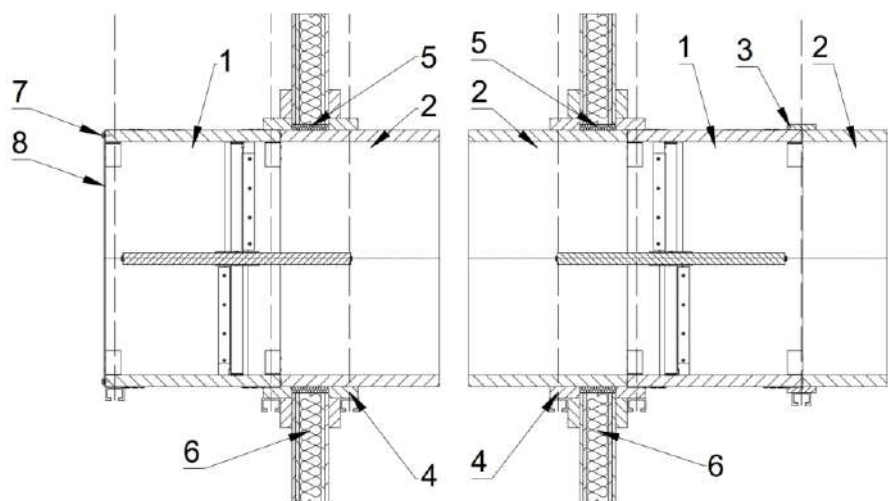

1. FID B BxH damper
2. Multi-zone smoke extract duct - e.g., made of fire-rated boards
3. A strip of fire-resistant board along the entire length of the side BxH
4. System of ceiling hanger
5. System of installation transition of the fireproof duct
6. Panel wall
7. M10x20 screw
8. MWB system grille (accessory)

6.3.02 INSTALLATION OF DAMPER IN SOLID WALLS

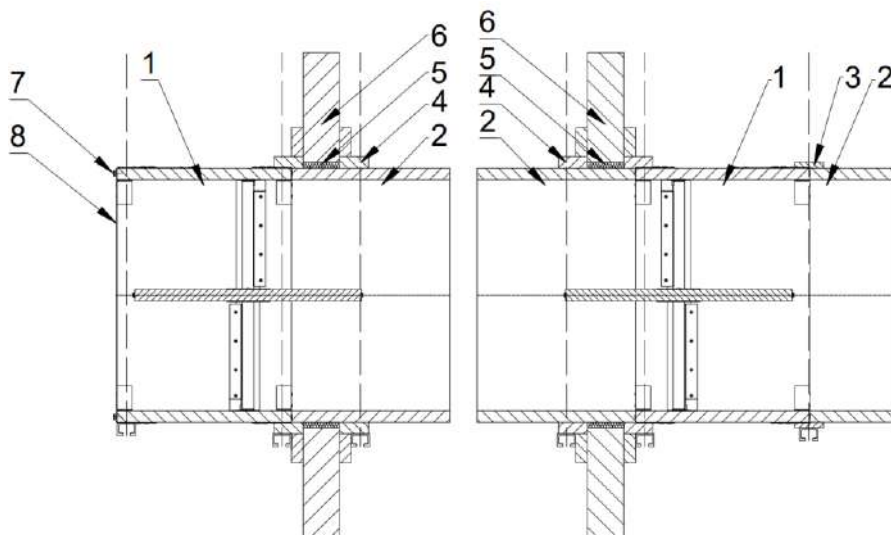

1. FID B BxH damper
2. Multi-zone smoke extract duct - e.g., made of fire-rated boards
3. A strip of fire-resistant board along the entire length of the side BxH
4. System of ceiling hanger
5. System of installation transition of the fireproof duct
6. Panel wall
7. M10x20 screw
8. MWB system grille (accessory)

6.3.03 INSTALLATION OF DAMPER IN RIGID FLOOR - ABOVE THE RIGID FLOOR

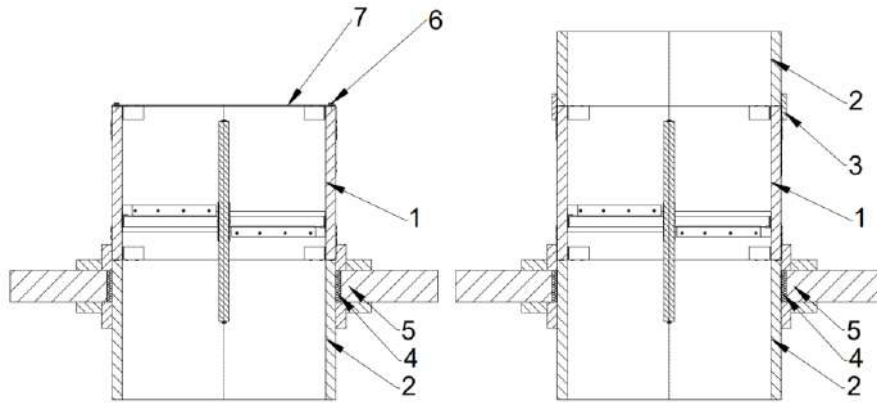

1. FID B BxH damper
2. Multi-zone smoke extract duct - e.g., made of fire-rated boards
3. A strip of fire-resistant board along the entire length of the side BxH
4. System of installation transition of the fireproof duct
5. Rigid floor
6. M10x20 screw
7. MWB system grille (accessory)

6.3.04 INSTALLATION OF DAMPER IN RIGID FLOOR - BELOW THE RIGID FLOOR

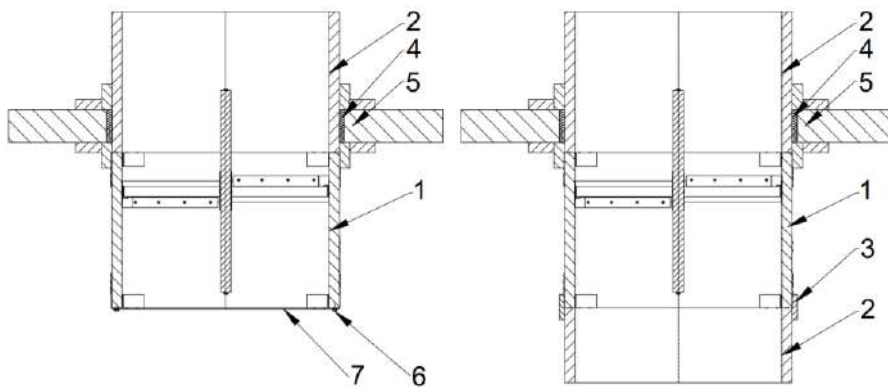

1. FID B BxH damper
2. Multi-zone smoke extract duct - e.g., made of fire-rated boards
3. A strip of fire-resistant board along the entire length of the side BxH
4. System of installation transition of the fireproof duct
5. Rigid floor
6. M10x20 screw
7. MWB system grille (accessory)

6.3.05 INSTALLATION OF THE DAMPER ON HORIZONTAL DUCTS

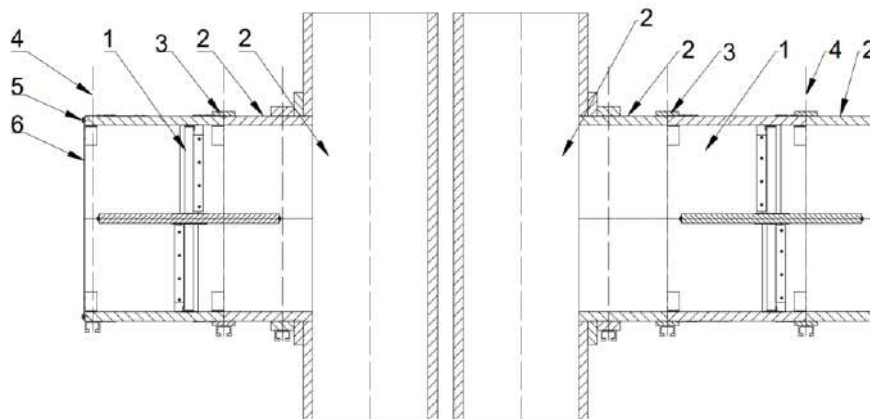

1. FID B BxH damper
2. Multi-zone smoke extract duct - e.g., made of fire-rated boards
3. A strip of fire-resistant board along the entire length of the side BxH
4. System of ceiling hanger
5. M10x20 screw
6. MWB system grille (accessory)

6.3.06 INSTALLATION OF THE DAMPER ON VERTICAL DUCTS

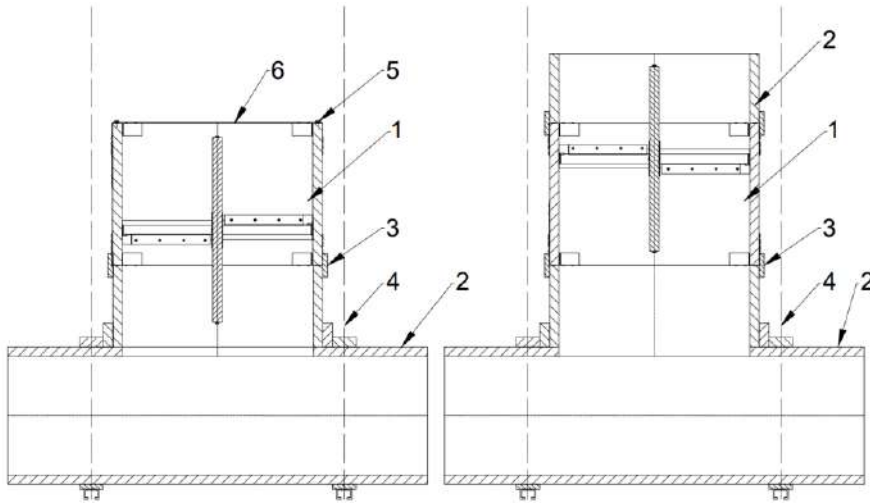

1. FID B BxH damper
2. Multi-zone smoke extract duct - e.g., made of fire-rated boards
3. A strip of fire-resistant board along the entire length of the side BxH
4. System of ceiling hanger
5. M10x20 screw
6. MWB system grille (accessory)

6.3.07 INSTALLATION OF THE DAMPER ON VERTICAL DUCTS 2

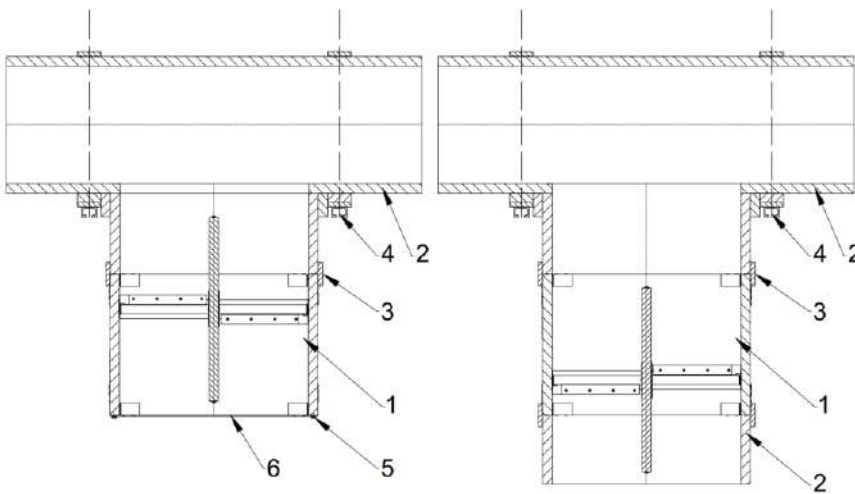

1. FID B BxH damper
2. Multi-zone smoke extract duct - eg made of fire-rated boards
3. A strip of fire-resistant board along the entire length of the side BxH
4. System of ceiling hanger
5. M10x20 screw
6. MWB system grille (accessory)

6.3.08 CONNECTION OF A MULTI-ZONE FIREPROOF DUCT, E.G. MADE OF FIRE RATED BOARDS

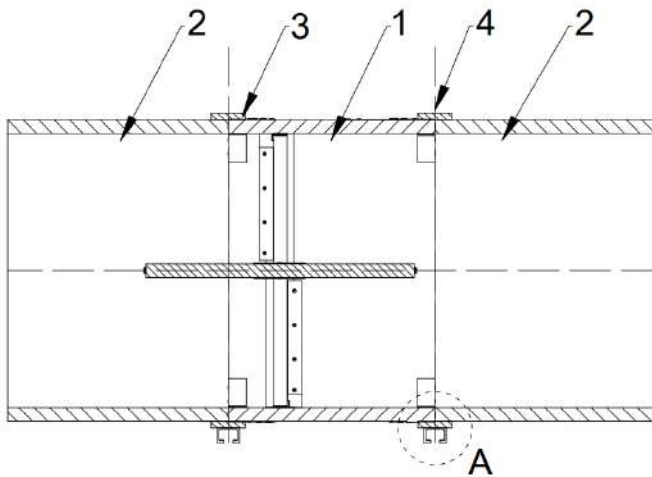

1. FID B BxH damper
2. Multi-zone smoke extract duct - e.g., made of fire-rated boards
3. A strip of fire-resistant board along the entire length of the side BxH
4. System of ceiling hanger
5. A strip of fire-resistant board along the entire length of the side BxH with dimensions 10x50mm
6. A strip of fire-resistant board along the entire length of the side BxH with dimensions 20x50mm

Variants of detail A:

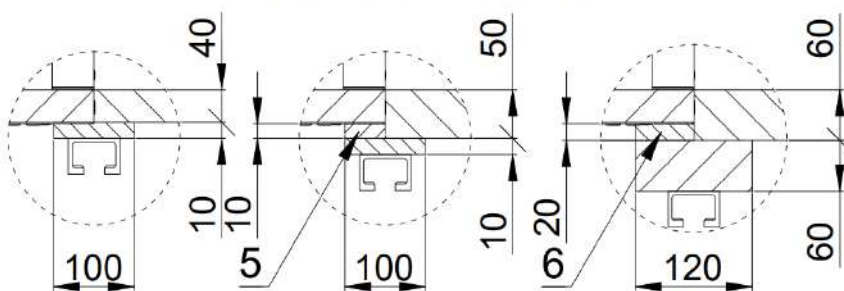

6.3.09 CONNECTION OF A SINGLE COMPARTMENT FIREPROOF DUCT, E.G. MADE OF METAL SHEETS

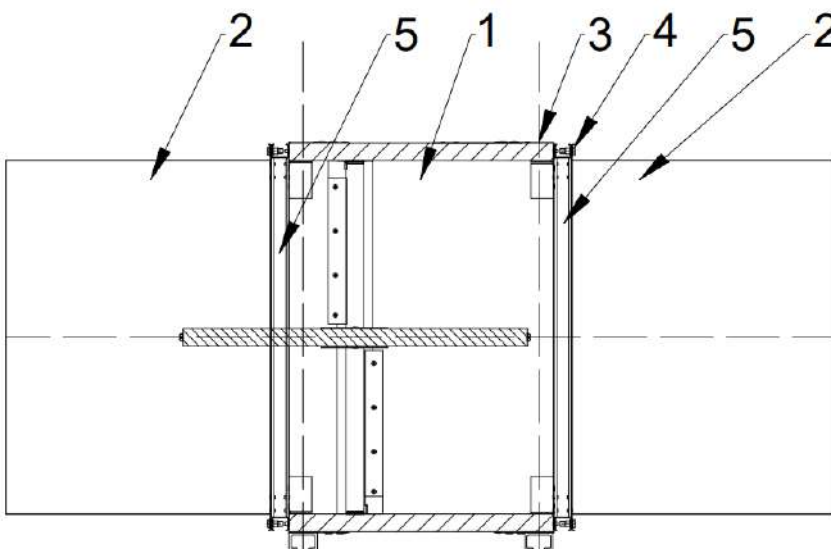

1. FID B BxH damper
2. Single-compartment smoke extract duct - e.g., metal one
3. System of ceiling hanger
4. M10x20 screw
5. RB mounting frame

CAUTION!

Smoke extraction duct should be made in accordance with the duct manufacturer's guidelines. The ducts must have adequate fire resistance in accordance with the fire resistance provided for the entire solution. Seal all connections between the damper and the ducts with appropriate mortar / glue / gaskets, ensuring fire resistance. The cut off damper in vertical position fire ventilation systems may be mounted across the horizontal smoke extract duct or on the sides of the horizontal smoke extract duct or on the surface of any side of the vertical smoke extract duct.

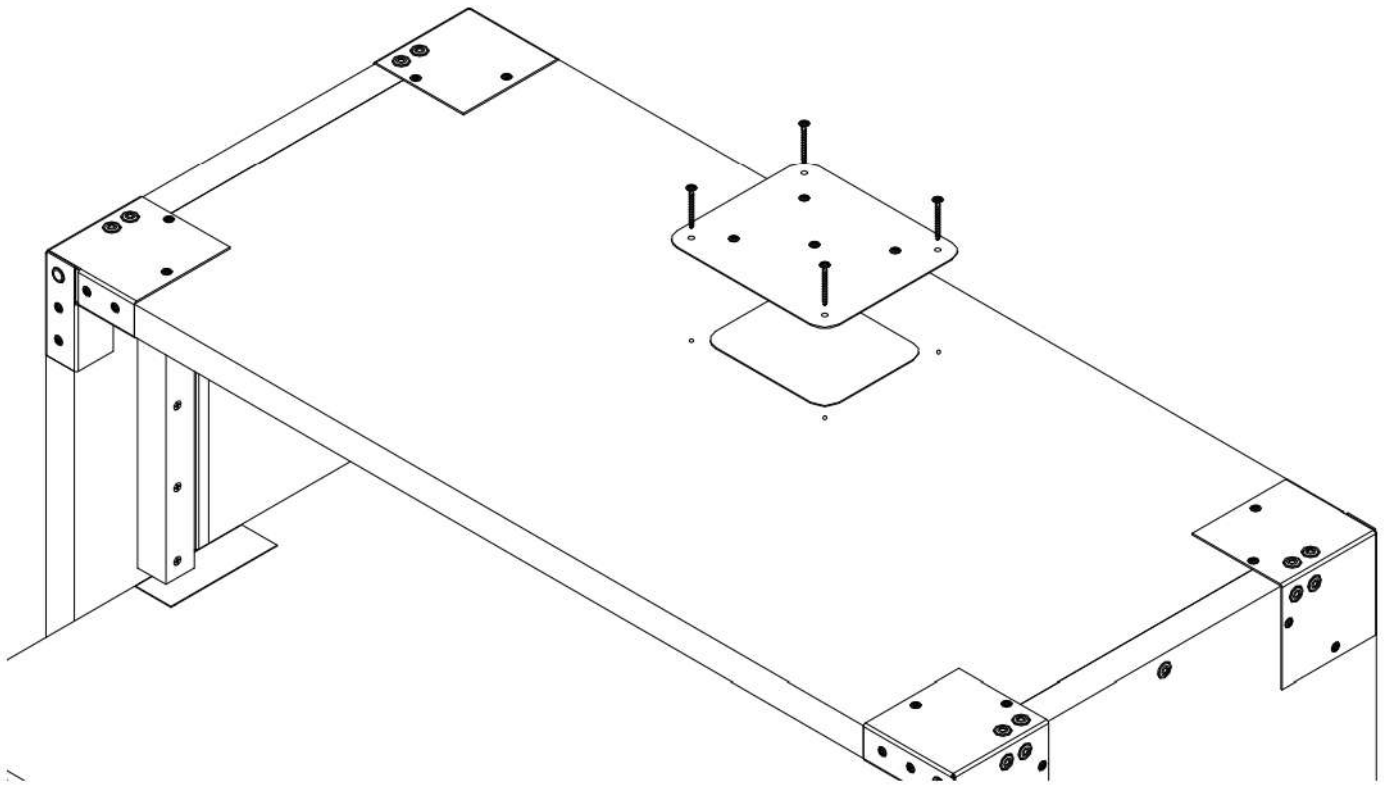

6.3.10 INSPECTION ACCESS

The FID B damper is factory-equipped with an access inspection, thanks to which the connected duct and the damper can be inspected without the need to disassemble the installation. The inspection can be opened by unscrewing the 4 extreme screws as shown in the drawing above.

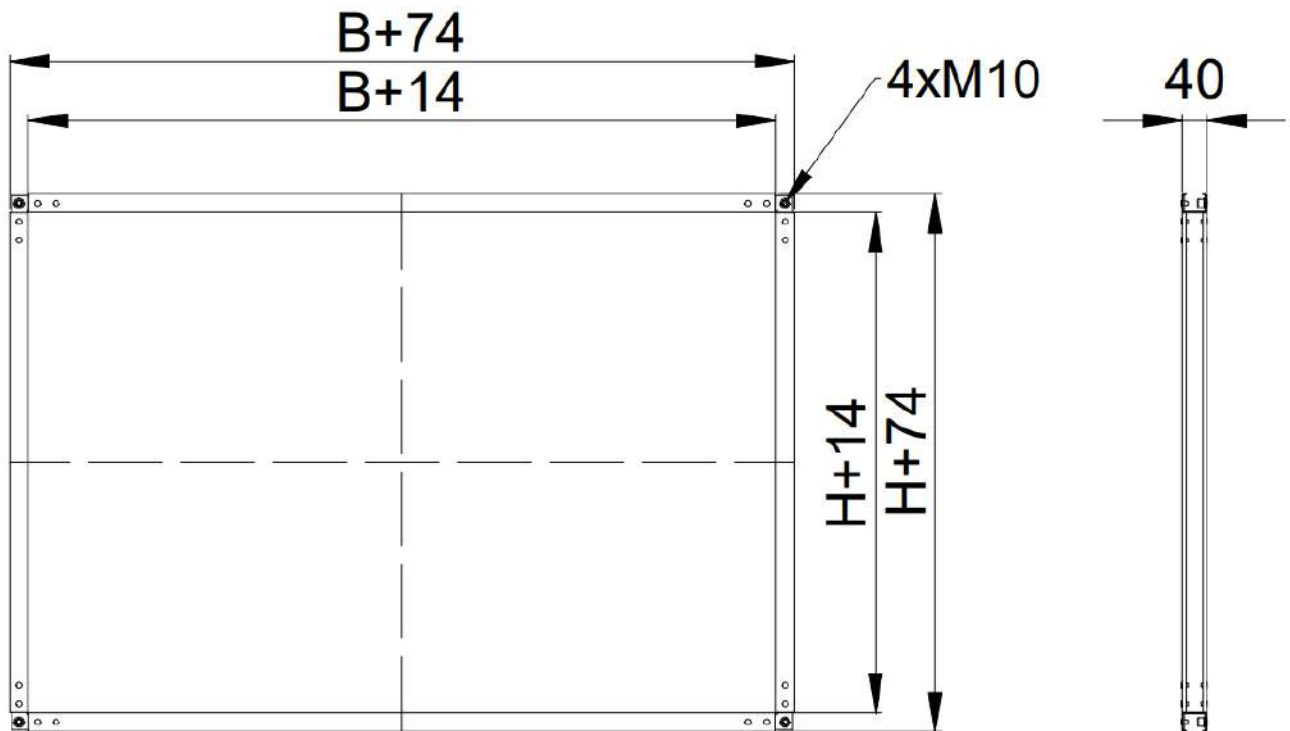

6.3.11 RB CONNECTION SUBFRAME

The FID B damper can be delivered by the manufacturer with a system assembly frame for single-compartment fire ventilation ducts. Flanges allow the connection of ventilation ducts with the use of clamps for fixing ducts. M10 rivet nuts located in the corners of the frame allow for centering the ducts. If the RB assembly frame is assembled on its own, the connection should be sealed with fire rated material that provides the appropriate fire resistance for the application.

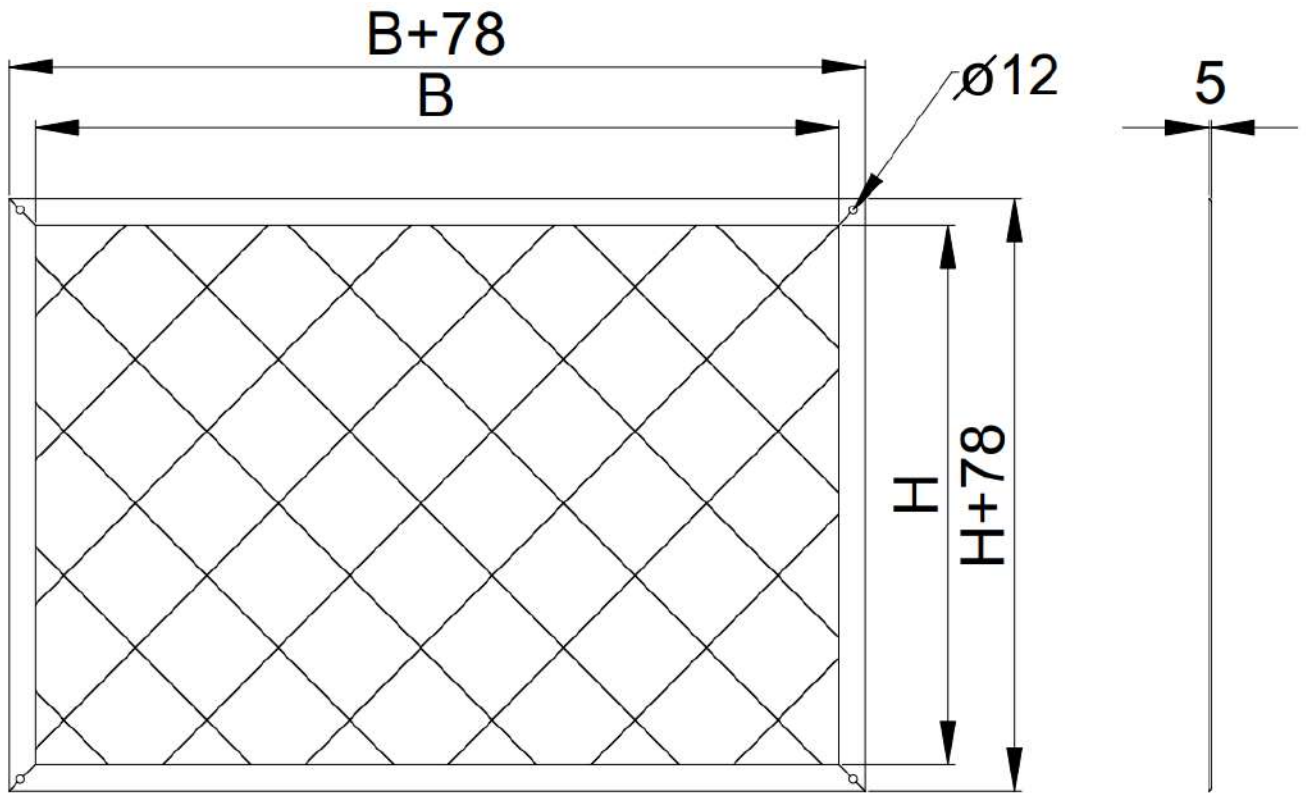

6.3.12 MWB SYSTEM GRILLE

The FID B damper can be delivered by the manufacturer with a system cover grille. In case of specific architectural requirements, the structure of the system masking grilles allows covering the damper and the grille with additional masking grilles.

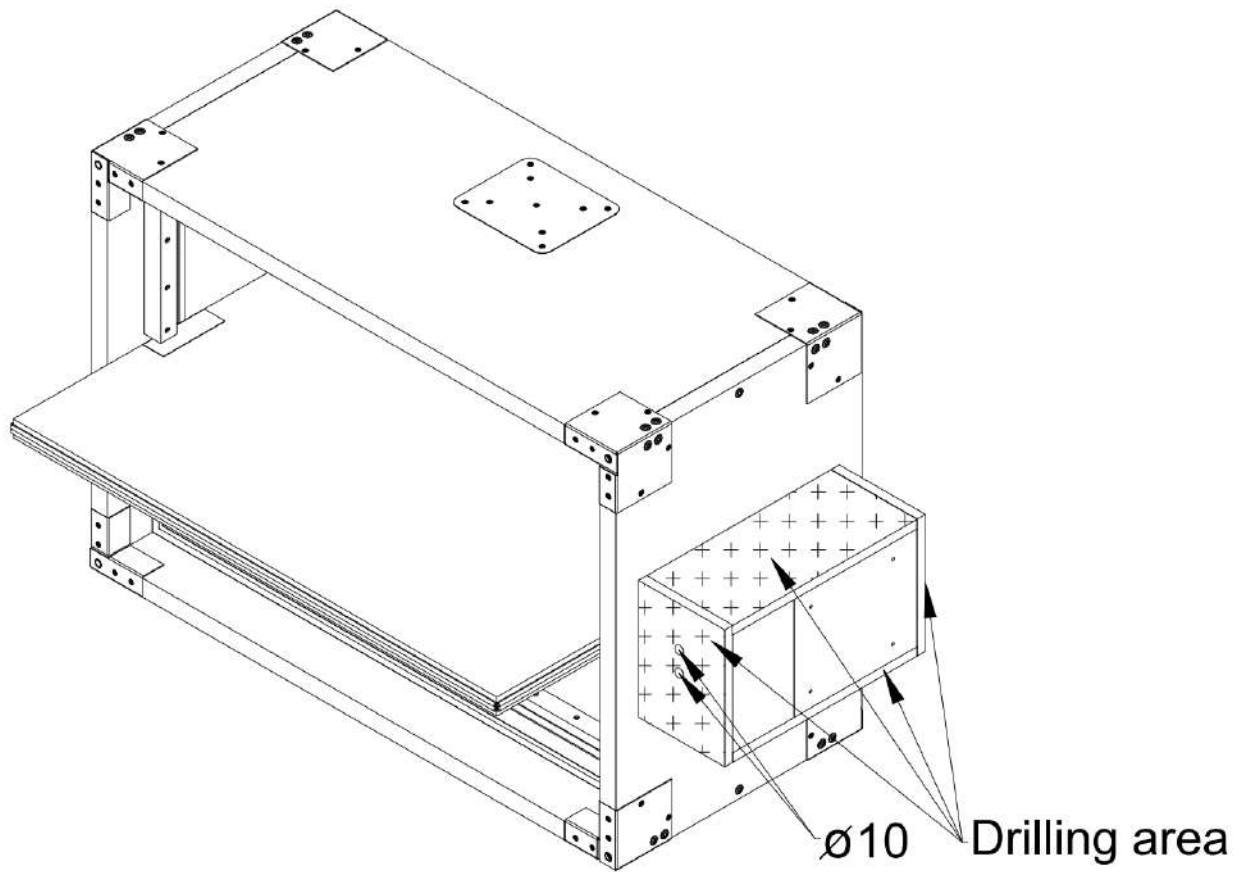

6.3.13 INTRODUCTION OF ELECTRIC CABLES FOR ELECTRIC POWER SUPPLY OF THE ACTUATOR

The introduction of electric cables to power the actuator should be done by drilling the actuator casing with a Ø10 drill. The openings can be made in any plane of the casing marked in the drawing above. After inserting the cables, fill the gap between the cable and the actuator housing with fire rated material ensuring appropriate fire resistance, provided for the application, or use appropriate electric glands. The power and control cables must have adequate fire resistance that guarantees the supply of the control signal to the device in the event of a fire.

6.4 ACTUATORS

With the fire damper properly installed and embedded connect the electrical system wiring to the fire damper if the device features controls or other parts that require electric power supply. The following shows the connection diagrams and basic electrical data for the trigger control gears supplied with the FID B fire dampers.

6.4.01 TYPES OF ELECTRIC ACTUATORS

ACTUATOR TYPE	LOCATION OF THE DAMPER ISOLATION PARTITION
<ul style="list-style-type: none"> - Belimo BFL series - Belimo BFN series - Belimo BF series - Mercor MLF series - Mercor MF series 	Open isolation partition - actuator indication: 90 Closed isolation partition - actuator indication: 0
<ul style="list-style-type: none"> - Belimo serii BE - Belimo serii BLE - Belimo serii BEE - Belimo serii BEN 	Open isolation partition - actuator indication: 0 Closed isolation partition - actuator indication: 90

6.4.02 TECHNICAL SPECIFICATIONS OF ELECTRICAL ACTUATORS

6.4.02.01 TECHNICAL SPECIFICATIONS FOR THE BF24, BF24-T, BF24-TN, MF 24T, BF230, BF230, BF230-T, BF230-TN, AND MF 230T ACTUATORS

TECHNICAL SPECIFICATIONS	BF 24, BF24-T, BF24-TN, MF 24T	BF230, BF230-T, BF230-TN, MF 230T
POWER SUPPLY	AC 24V 50/60Hz DC 24V	AC 220-240V 50/60 Hz
POWER DEMAND:		
- FOR SPRING TENSIONING	7 W	8,5 W
- FOR SPRING HOLDING	2 W	3 W
SIZING (APPARENT POWER)	10 VA	11 VA
APPLIANCE CLASS	III	II
INGRESS PROTECTION RATING	IP 54	IP 54
AUXILIARY CIRCUIT BREAKER:	2xSPDT	2xSPDT
- ACTIVATION POSITION [DEGREES]	6 (3) A, 250V 5°, 80°	3 A, 250V~ 5°, 80°
TORQUE:		
- MOTOR	18 Nm	18 Nm
- SPRING	12 Nm	12 Nm
CABLE CONNECTION:		
- MOTOR (L = 0.9 M)	2x0,75 mm ²	2x0,75 mm ²
- AUXILIARY CIRCUIT BREAKER	6x0,75 mm ²	6x0,75 mm ²
MOVEMENT TIME: (0-90°)		
- MOTOR	120 s	120 s
- RETURN SPRING	16 s	16 s
OPERATING TEMPERATURE RANGE	- 30 ...+50°C	- 30 ...+50°C
SOUND PRESSURE LEVEL:		
- MOTOR	max 45 dB (A)	max 45 dB (A)
- SPRING	~ 63 dB (A)	~ 63 dB (A)

6.4.02.02 TECHNICAL SPECIFICATIONS FOR THE BE24, BE24-ST, BE230, BLE24, BLE24-ST AND BLE230 ACTUATORS

TECHNICAL SPECIFICATIONS	BE24, BE24-ST	BE230	BLE24, BLE24-ST	BLE230
POWER SUPPLY	AC 24V 50/60Hz DC 24 V	AC 220-240V 50/60 Hz	AC 24V 50/60Hz DC 24V	AC 220-240V 50/60 Hz
POWER DEMAND:				
- FOR SPRING TENSIONING	12 W	8 W	7.5 W	5 W
- FOR SPRING HOLDING	0,5 W	0,5 W	0,5 W	1 W
SIZING (APPARENT POWER)	18 VA	15 VA	9 VA	12 VA
APPLIANCE CLASS	III	II	III	II
INGRESS PROTECTION RATING	IP 54	IP 54	IP 54	IP 54
AUXILIARY CIRCUIT BREAKER:	2xSPDT 6(3) A, 250V	2xSPDT 6(3) A, 250V	2xSPDT 3A, AC 250V	2xSPDT 3A, AC 250V
- ACTIVATION POSITION	3°, 87°	3°, 87°	3°, 87°	3°, 87°
TORQUE:				
- MOTOR	40 Nm	40 Nm	15 Nm	15 Nm
- LOCKING	50 Nm	50 Nm	20 Nm	20 Nm
CABLE CONNECTION:				
- MOTOR (L = 0.9 M)	3x0,75 mm ²	3x0,75 mm ²	3x0,75 mm ²	3x0,75 mm ²
- AUXILIARY CIRCUIT BREAKER	6x0,75 mm ²	6x0,75 mm ²	6x0,75 mm ²	6x0,75 mm ²
MOVEMENT TIME: (0-90°)				
- MOTOR	60s	60s	60s	60s
OPERATING TEMPERATURE RANGE	- 30 ...+50°C	- 30 ...+50°C	- 30 ...+50°C	- 30 ...+50°C
SOUND PRESSURE LEVEL:				
- MOTOR	max 62 dB (A)	max 62 dB (A)	max 62 dB (A)	max 62 dB (A)

6.4.02.03 TECHNICAL SPECIFICATIONS FOR THE BEE24, BEE24-ST, BEE230, BEN24, BEN24-ST AND BEN230 ACTUATORS

TECHNICAL SPECIFICATIONS	BEE24, BEE24-ST	BEE230	BEN24, BEN24-ST	BEN230
POWER SUPPLY	AC 24V 50/60Hz DC 24 V	AC 220-240V 50/60 Hz	AC 24V 50/60Hz DC 24V	AC 220-240V 50/60 Hz
POWER DEMAND:				
- FOR SPRING TENSIONING	2,5 W	3,5 W	3 W	4 W
- FOR SPRING HOLDING	0,1 W	0,4 W	0,1 W	0,4 W
SIZING (APPARENT POWER)	5 VA	6 VA	6 VA	7 VA
APPLIANCE CLASS	III	II	III	II
INGRESS PROTECTION RATING	IP 54	IP 54	IP 54	IP 54
AUXILIARY CIRCUIT BREAKER:	2xSPDT 3A AC 250V	2xSPDT 3A AC 250V	2xSPDT 3A, AC 250V	2xSPDT 3A, AC 250V
- ACTIVATION POSITION	5°, 80	5°, 80	5°, 80	5°, 80
TORQUE:				
- MOTOR	25 Nm	25 Nm	15 Nm	15 Nm
CABLE CONNECTION:				
- MOTOR (L = 0.9 M)	3x0,75 mm ²	3x0,75 mm ²	3x0,75 mm ²	3x0,75 mm ²
- AUXILIARY CIRCUIT BREAKER	6x0,75 mm ²	6x0,75 mm ²	6x0,75 mm ²	6x0,75 mm ²
MOVEMENT TIME: (0-90°)				
- MOTOR	60s	60s	30s	30s
OPERATING TEMPERATURE RANGE	- 30 ...+55°C	- 30 ...+55°C	- 30 ...+55°C	- 30 ...+55°C
SOUND PRESSURE LEVEL:				
- MOTOR	max 58 dB (A)	max 58 dB (A)	max 58 dB (A)	max 58 dB (A)

6.5.02.04 TECHNICAL SPECIFICATIONS FOR THE BFL24, BFL24-T, BFL230, BFL230-T, BFN24, BFN24-T, BFN230 AND BFN230-T

TECHNICAL SPECIFICATIONS	BFL24, BFL24-T	BFL230, BFL230-T	BFN24, BFN24-T	BFN230, BFN230-T
POWER SUPPLY	AC 24 V 50/60 Hz DC 24 V	AC 220-240 V 50/60 Hz	AC 24 V 50/60 Hz DC 24 V	AC 220-240 V 50/60 Hz
POWER DEMAND:				
- WHEN PUTTING THE SPRING UNDER TENSION	2.5 W	3,5 W	4 W	5 W
- WHEN IN STANDBY	0.7 W	1.1 W	1.4 W	2.1 W
APPARENT POWER	4 VA	6.5 VA	6 VA	10 VA
PROTECTION CLASS	III	II	III	II
IP RATING	IP 54	IP 54	IP 54	IP 54
AUXILIARY SWITCH:	2 x PDT	2 x PDT	2 x SPDT	2 x SPDT
- ACTIVATION POINT	3(0.5) A AC 250V 5°, 80°	3(0.5) A AC 250V 5°, 80°	3(0.5) A, 250 V 5°, 80°	3(0.5) A, 250 V 5°, 80°
TORQUE:				
- MOTOR	4 Nm	4 Nm	9 Nm	9 Nm
- SPRING	3 Nm	3 Nm	7 Nm	7 Nm
WIRE CONNECTION:				
- MOTOR (LENGTH: 0.9 M)	2 x 0.75 mm ²	2 x 0.75 mm ²	2 x 0.75 mm ²	2 x 0.75 mm ²
- AUXILIARY SWITCH	6 x 0.75 mm ²	6 x 0.75 mm ²	6 x 0.75 mm ²	6 x 0.75 mm ²
MOVEMENT TIME: (0-90°)				
- MOTOR	60 s	60 s	60 s	60 s
- RETURN SPRING	≈ 20 s	≈ 20 s	≈ 20 s	≈ 20 s
WORKING TEMPERATURE RANGE	-30 ...+55°C	-30 ...+55°C	-30 ...+55°C	-30 ...+55°C
SOUND PRESSURE LEVEL:				
- MOTOR	max 43 dB (A)	max 43 dB (A)	max 55 dB (A)	max 55 dB (A)
- SPRING	~ 62 dB (A)	~ 62 dB (A)	~ 67 dB (A)	~ 67 dB (A)

6.5.02.05 TECHNICAL SPECIFICATIONS FOR THE MLF 24T AND MLF 230T ACTUATORS

TECHNICAL SPECIFICATIONS	MLF 24T	MLF 230T
POWER SUPPLY	AC 24V 50/60Hz DC 24 V	AC 220-240V 50/60 Hz
POWER DEMAND:		
- FOR SPRING TENSIONING	5 W	5 W
- FOR SPRING HOLDING	2.5 W	3 W
SIZING (APPARENT POWER)	7 VA	7 VA
APPLIANCE CLASS	III	II
INGRESS PROTECTION RATING	IP 54	IP 54
AUXILIARY CIRCUIT BREAKER:	2xSPDT	2xSPDT
- ACTIVATION POSITION	6 (1.5)A AC 250V 5°, 80°	6 (1.5)A AC 250V 5°, 80°
TORQUE:		
- MOTOR	4 Nm	4 Nm
- SPRING	4 Nm	4 Nm
CABLE CONNECTION:		
- MOTOR (L = 0.9 M)	2x0.75 mm ²	2x0.75 mm ²
- AUXILIARY CIRCUIT BREAKER	6x0.75 mm ²	6x0.75 mm ²
MOVEMENT TIME: (0-90°)		
- MOTOR	40-75 s	40-75 s
- RETURN SPRING	≈20s	≈20s
OPERATING TEMPERATURE RANGE	- 30 ...+50°C	- 30 ...+50°C
SOUND PRESSURE LEVEL:		
- MOTOR	max. 45 dB (A)	max. 45 dB (A)
- SPRING	~ 62 dB (A)	~ 62 dB (A)

6.5.02.06 TECHNICAL SPECIFICATIONS FOR THE EXBF 24 AND EXBF 230 ACTUATORS

TECHNICAL SPECIFICATIONS	EXBF 24	EXBF 230
ZONE	1, 2, 21, 22	
ATEX CLASSIFICATION	II 2 GD EEx d IIC T6	
POWER SUPPLY :	24 V AC ±20% 50/60 Hz / 24 VDC-10/+20%	230 V AC ±14% 50/60 Hz
POWER DEMAND :		
- FOR SPRING TENSIONING	7 W	8 W
- FOR SPRING HOLDING	2 W	3 W
SIZING (APPARENT POWER)	10 VA	12.5 VA
INGRESS PROTECTION RATING	IP 66	IP 66
AUXILIARY CIRCUIT BREAKER:	2 x SPDT 6A (3) max 250 V AC	2 x SPDT 6A (3) max 250 V AC
- ACTIVATION POSITION	5°, 80°	5°, 80°
TORQUE:		
- MOTOR	18 Nm	18 Nm
- SPRING	12 Nm	12 Nm
MOVEMENT TIME: (90°)		
- MOTOR	150 s	150 s
- SPRING	≈20s	≈20s

6.6.01 CONNECTION DIAGRAMS OF ELECTRICAL ACTUATORS

6.6.01.01 CONNECTION DIAGRAM FOR THE BF24T and BF230-T ACTUATORS

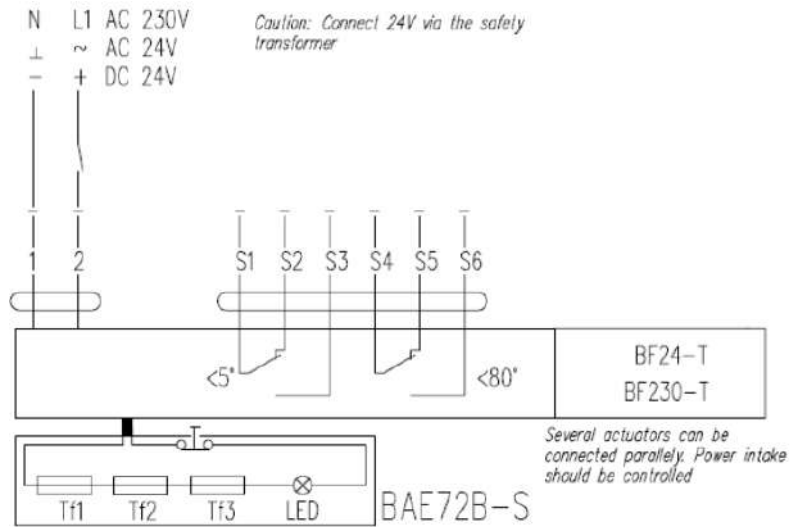

6.6.01.02 CONNECTION DIAGRAM FOR THE BFL24-T, BFL230-T, BFN24-T, BFN230-T, BF24-TN AND BF230-TN ACTUATORS

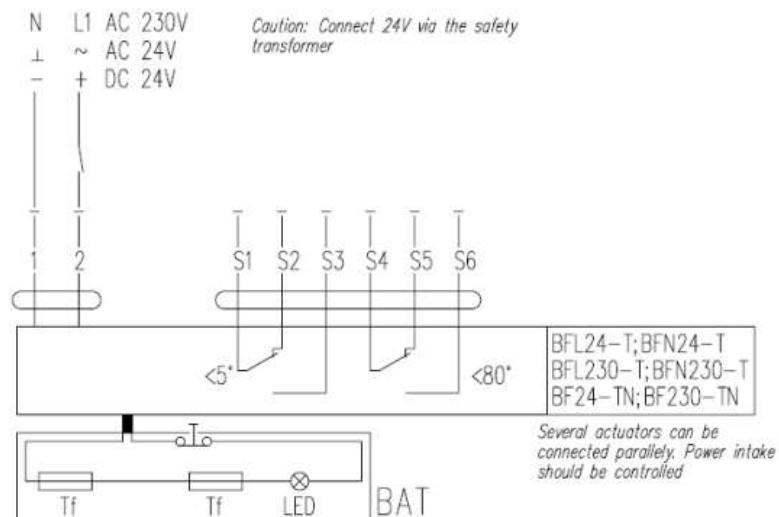

6.6.01.03 CONNECTION DIAGRAM FOR THE MLF 24T, MLF 230T, MF 24T AND MF 230T ACTUATORS

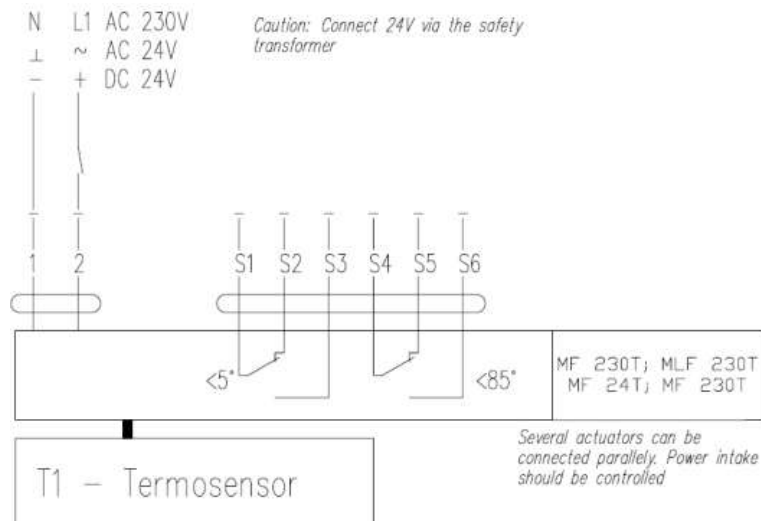

6.6.01.04 CONNECTION DIAGRAM FOR THE BE24, BLE24, BE230 AND BLE230 ACTUATORS

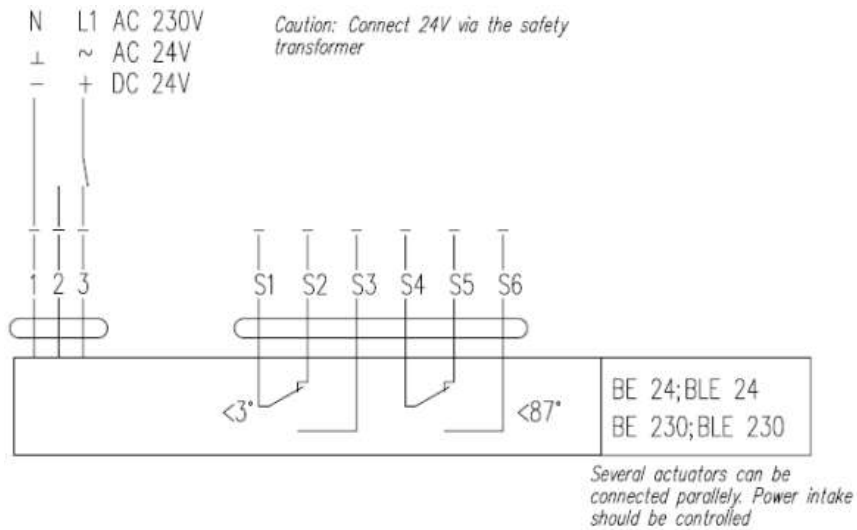

6.6.01.05 CONNECTION DIAGRAM FOR BEE24, BEN24, BEE230 AND BEN230 ACTUATORS

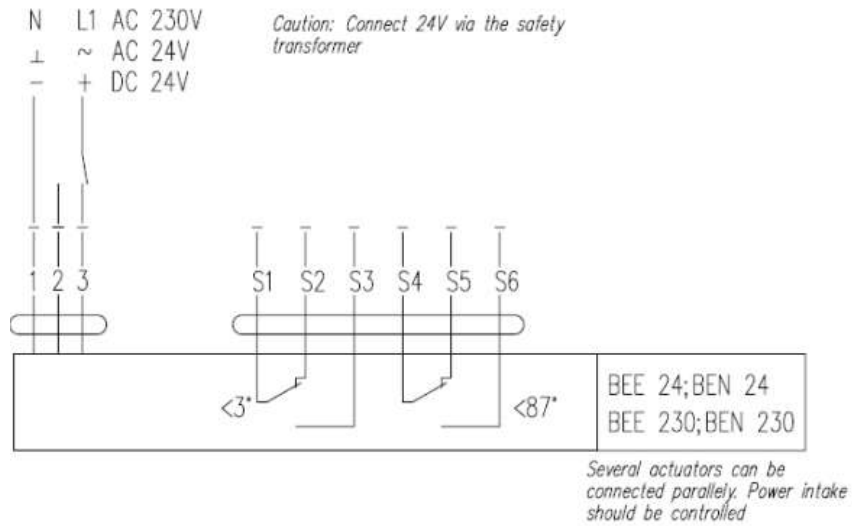

NOTE:

The BE, BLE, BEE and BEN actuator operating control requires a three-wire system. The actuator sense of rotation is switched by applying the supply voltage to terminal 2 or 3, depending on the desired sense. The location of the limit switches for all types of actuators is shown for the position without voltage. For proper operation of a device equipped with electrical actuators, it is recommended that the rated voltage housed tolerance of 24V±10% or 230V±10%. Power supply devices other than listed above may cause malfunction and will not be covered by the warranty conditions.

6.6.01.06 CONNECTION DIAGRAM FOR THE EXBF ACTUATORS

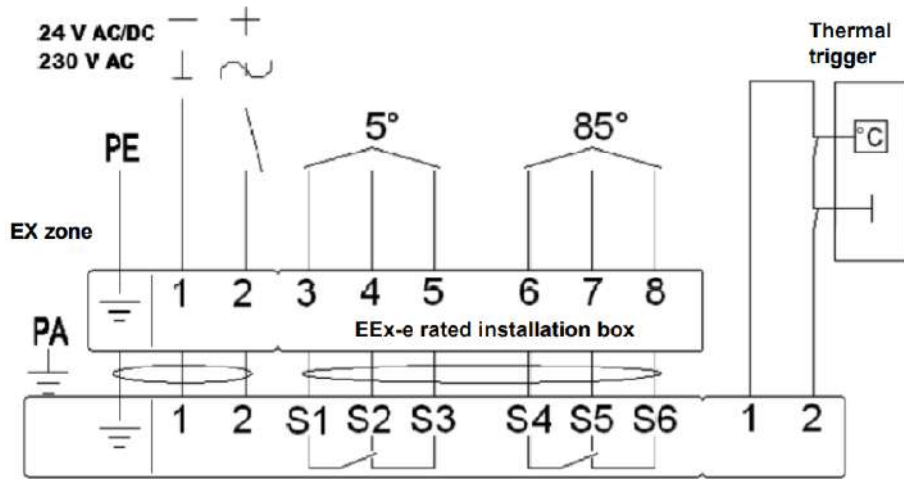

CAUTION!

For proper operation of a device equipped with electrical actuators, it is recommended that the rated voltage housed tolerance of 24V±10% or 230V±10%. Power supply devices other than listed above may cause malfunction and will not be covered by the warranty conditions.

6.7 RST/KW1 TRIGGER CONTROL GEAR

The RST/KW1/S version has the limit switches installed in the gear itself. The electrical connections shall be made by connecting the properly labelled conductors to the electrical system. A fusible trigger is installed in the gear. The dampers with the RST/KW1/230I, RST/KW1/230P mechanisms, are supplied with the RST/KW1/24... triggering and control mechanism, together with the 230/24V transformer module type MP230/24. For the trigger and control mechanism of the "impulse" type damper, adequate power must be provided to ensure that the control signal is supplied to the device in the event of fire.

6.7.01 TECHNICAL SPECIFIKATIONS FOR RST/KW1/S, RST/KW1/24I, RST/KW1/24P, RST/KW1/24I+MP230/24 AND RST/KW1/24I+MP230/24 TRIGGER CONTROL GEARS

	RST/KW1/S	RST/KW1/24I	RST/KW1/24P	RST/KW1/24I+MP230/24	RST/KW1/24I+MP230/24
SUPPLY VOLTAGE	X	24 V – 48 V DC	24 V – 48 V DC	230V AC	230V AC
POWER CONSUMPTION	X	3.5 W	1.6 W	4.5 W	2.5 W
HOLDING FORCE	X	12 daN	12 daN	12 daN	12 daN
THERMAL TRIGGER TRIP POINT		72°C +-2°C			
WK1D / WK2D LIMIT SWITCH		NO/NC (switching contact) 5A, 230V AC			
SWITCH TRIGGER		3°, 87° - tolerance: +/- 2°			
LIMIT SWITCH OPERATING TEMPERATURE		-25 ...+85°C			
ELECTRICAL CONNECTION	X	- release: cable 0.6 m, 2x0.5 mm2 - limit switch: cable 0.6 m, 6x0.5 mm2			

ROTATION ANGLE	92°				
MOVEMENT TIME	Max. 2s - spring				
SENSE OF ROTATION	CCW				
GEAR WEIGHT	1.2 kg	1.4 kg	1.4 kg	1.5 kg	1.5 kg

KW1 GEAR POWER SUPPLY:	WK1 LIMIT SWITCH	WK2 LIMIT SWITCH
Wire number: 1-2	Wire number: 3-4 - NO (normally open) Wire color: green / gray Wire number: 4-5 - NC (normally closed) Wire color: gray / blue	Wire number: 6-7 - NO (normally open) Wire color: brown / pink Wire number: 7-8 - NC (normally closed) Wire color: pink / yellow

6.7.02 CONNECTION DIAGRAM FOR TRANSFORMER MODULE TYPE MP230/24

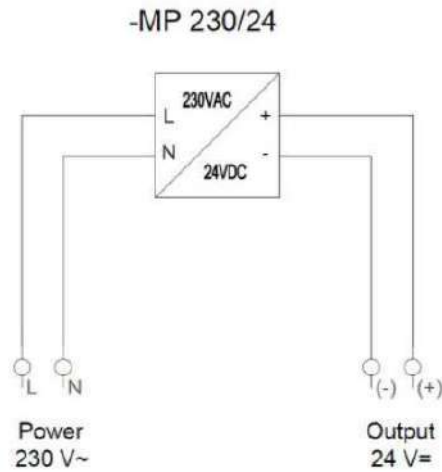

CAUTION! - The location of the limit switches is shown for the fire damper in the safety position.

CAUTION!

For proper operation of a device equipped with electrical actuators, it is recommended that the rated voltage housed tolerance of $24V \pm 2\%$ or $230V \pm 2\%$. Power supply devices other than listed above may cause malfunction and will not be covered by the warranty conditions.

In the RST version the limit switches are independent units installed inside the fire damper casing. The fusible release is located on the damper isolation partition. The driving spring is installed on the damper isolation partition.

Installation of the RST fusible release:

- Move partition to the open position
- Install the fusible link on the hooks attached to the fire damper casing and the isolation partition
- Tighten the nut to lock the hook on the fire damper casing

CAUTION!

The drawing is indicative only and applies both to the rectangular and circular form versions.

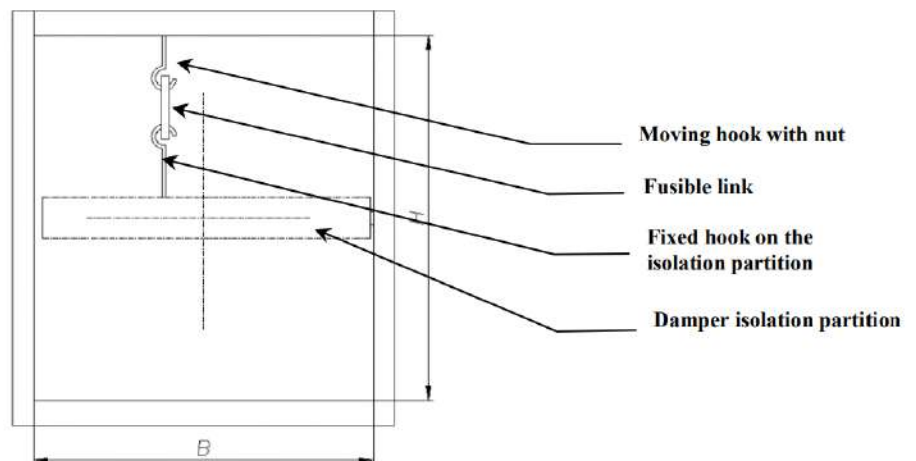

- 230V±2% for electromagnetic release mechanism
- Check the equipment casing, especially for all mechanical damage.
- Check for any obstructions to proper performance of the equipment.

To facilitate the activities under service inspection, servicing and warranty claim response, e.g., visual inspection or repairs, the equipment user/operator shall provide physical access to the equipment by removing thermal insulation, suspended ceiling, and other installations, as required and applicable to warrant unobstructed access.

Inspection ports, e.g., type mcr KRW are recommended for equipment installed in ducts. In the case of roof mounted equipment, provide access to the area (via ladders or elevated platforms).

9. WARRANTY TERMS AND CONDITIONS

1. Safevent ApS grants 12 months of warranty for the equipment quality from the date of purchase, unless the sales contract states otherwise.
2. Submit each warranty claim to Safevent ApS in 7 days from the date of discovery of a warranty eligible defect.
3. Submit warranty claims by calling at tel.: +45 88 63 89 00 or by e-mail: sales@safevent.dk.
4. If physical defects of equipment are found during the warranty period, Safevent ApS warrants and represents to remove them in shortest possible time from serving the written warranty claim with the proof of purchase or sales contract, subject to Item 10.
5. Safevent ApS has the right to extend the time of repair if the defect removal is complicated or requires purchase of custom components or spare parts.
6. The warranty liability only covers all defects arising from causes present in the equipment at the date of sale.
7. Defects caused by improper operation or otherwise as listed in Item 10 herein, the buyer / warranty beneficiary will be charged with the costs of their removal.
8. Condition for rectifying defects is that the applicant makes the site/localisation where devices are installed available, in particular, ensuring: the lift in the case of devices mounted at a height above 3m, free access to the rooms where the devices were installed and necessary revisions, dismantling thermal insulation, disassembling suspended ceilings, disassembling other installations, if they prevent free access to the device.
9. If the device can not be repaired at the place of its installation, Safevent ApS reserves the necessity of its disassembly, possible delivery to the address indicated by Safevent ApS and re-assembly. The cost of this operation lies with the buyer / holder of the guarantee.
10. The warranty does not cover:
 - Any damage or failure of the equipment caused by improper operation, tampering, failure to conduct periodic technical inspection and/or maintenance established in this operation and maintenance manual, section "SERVICING AND MAINTENANCE".
 - Any damage beyond reasonable control of Safevent ApS, and specifically: caused by force majeure, such as torrential rainfall, flooding, hurricanes, inundation, lightning strike, power grid overvoltage, explosion, hail, collision with aircraft, fire, avalanche, landslide and indirect damage due to those causes. Torrential rainfall is understood as any rainfall with the effectiveness factor of 4 or higher in accordance with the definition of the Polish Institute of Meteorology and Water Management - National Research Institute (IMGW-PIB). If the effectiveness factor value specified in the preceding sentence cannot be reasonably established, the actual condition and extent of damage shall be considered at the site of their origin as the action of torrential rain. Hurricane is understood as any wind with a minimum speed of 17.5 m/s (and damage shall be recognised as caused by hurricanes if the effects of such weather phenomenon has been found in the direct vicinity of the damaged property).
 - Damage due to failure to immediately report any defect found.
 - Deterioration in the quality of coatings due to natural weathering/ageing.
 - Defects caused by abrasive or aggressive cleaning agents.

- Damage caused by aggressive external influence, specifically chemical or biological in nature, or when the origin of which is related to the production processing or activity carried out within the facility protected by the equipment or in its direct vicinity.
 - Wearing parts and consumables (e.g. gaskets/seals), unless they have defects of workmanship and/or material.
 - Damage caused by improper transport, handling, unloading and/or storage of the equipment.
 - Damage caused by installation of the equipment in violation of this operation and maintenance manual and/or good construction practice.
 - The equipment and/or parts thereof with removed or damaged nameplate (rating plate) and/or warranty seals.
11. The buyer/warranty rights holder is required to operate the equipment properly and carry out technical inspection and maintenance in accordance with the section "MAINTENANCE AND SERVICING" in the following this operation and maintenance manual.
12. This warranty shall be made immediately void and null if:
- The buyer/warranty rights holder modifies the product design without prior authorisation from Safevent ApS.
 - Periodic technical inspection and/or maintenance is not carried out per schedule and/or is carried out by unauthorised personnel or service providers not authorised to do so by Safevent ApS and/or the equipment has not been properly operated.
 - Unauthorised personnel attempts any intervention in the product outside of the normal operation and maintenance of this equipment.
 - The device's thermal trigger was affected by a temperature greater than Tmax (page 2 of this operation and maintenance manual).
13. Any circumstances listed in Item 10 will relieve Safevent ApS from the obligation of surety.

SAFEVENT ApS

Mads Clausens Vej 6
DK-9800 Hjoerring
Denmark

TEL: +45 88 63 89 00
MAIL: sales@safevent.dk
URL: www.safevent.dk/en

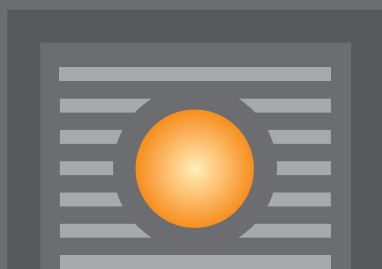
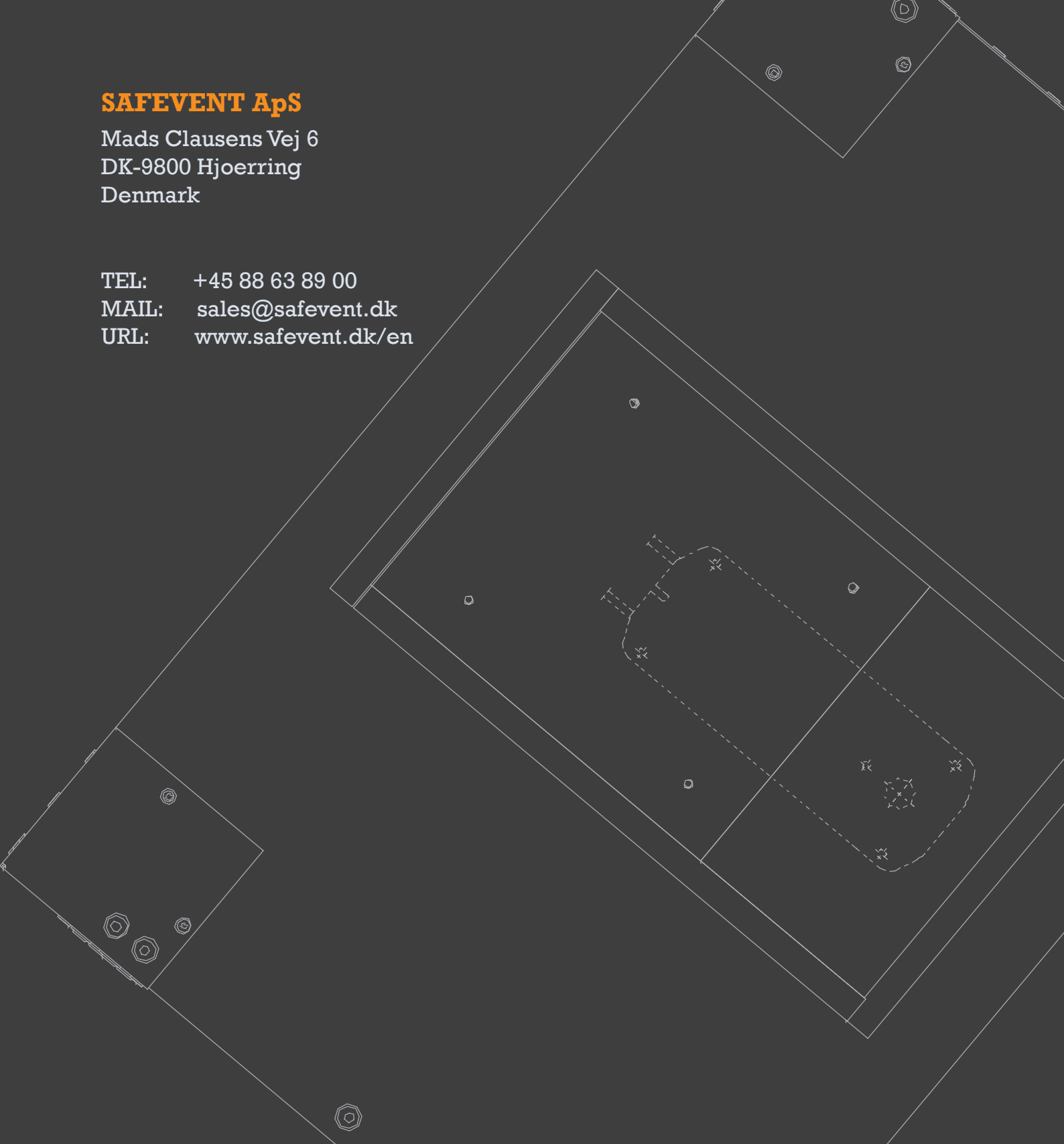

SAFE • VENT®