

Fire damper:



Multi-blade smoke exhaust fire dampers for multi-zone fire ventilation systems

Model WIP/V & WIP/V-M

Technical Catalogue

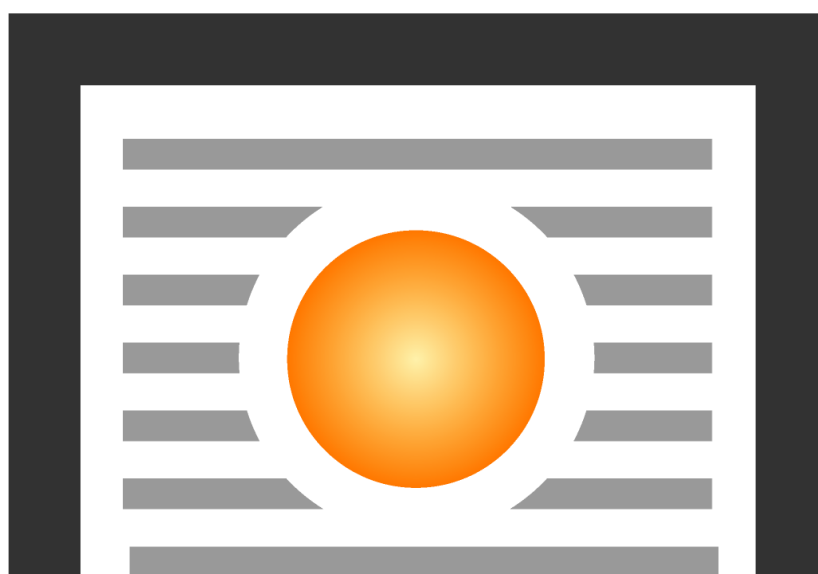

SAFE • VENT[®]

Table of content

1. Application	4
2. Design	5
3. Versions	5
3.1 WIP/V, WIP/V-M – smoke exhaust fire dampers for multi-zone fire ventilation systems with an actuator – damper closing and opening with an actuator	5
4. Dimensions	6
5. Installation	6
5.1 Preparation of installation openings	6
5.2 Sample installation in concrete or masonry walls	7
5.3 Sample installation in concrete block or full brick walls	8
5.4 Sample installation in ceiling	8
5.5 Sample installation outside the fire partition	9
5.6 Sample installation in a multiple set (a battery of four dampers)	9
5.7 Fire damper installation with vertical rotation axis of the louvers	10
5.8 Distance between systems and partitions	10
5.9 Example applications – installation with masking cover	11
6. Technical parameters of WIP/V, WIP/V-M rectangular dampers	12
7. Estimated Weights of WIP/V, WIP/V-M dampers [kg]	17
8. Marking	17
9. Power Supply Control	18
9.1 Cooperation with smoke exhaust/cut-off dampers – drive quick selection table	18
9.2 Actuators	19
9.2.1 BF electric actuators	19
9.2.2 BE, BLE electric actuators	21
9.2.3 BFL, BFN ELECTRIC ACTUATORS	22
9.2.4 EXBF actuators	23
9.3 RST trigger control mechanisms	24
9.3.1 Independent limit switches – RST version	24
9.3.2 Switch specifications	24
9.4 RST-KW1 mechanisms	25
9.4.1 Description of electrical connections:	25
9.5 Manufacture standards	26
9.5.1 FID S/S c/P damper	26
9.5.2 FID S/S p/P, FID S/S p/O, FID S/V p/P damper	27
9.5.3 FID PRO/S damper	27

9.5.4 WIP/S, WIP/V, WIP/V-M, WIP/T, WIP/T-G damper.....	27
9.5.5 WIP PRO/S, WIP PRO/V, WIP PRO/V-M damper with an actuator	27
9.5.6 WIP PRO/S, WIP PRO/V, VIP PRO/V-M damper with RST-KW1 mechanism	28



ATEST HIGIENICZNY



- EI120
- Certificate of constancy of performance 1396-CPR-0117.
- Dampers certified for compliance with EN 12101-8.
- Dampers qualified under EN 13501-4 and tested under EN 1366-10.
- Narrow louvered fire dampers for fire ventilation systems.

1. Application

Multi-blade WIP/V, WIP/V-M fire dampers are designed for use in automatic fire ventilation systems.

WIP/V fire dampers are used in fire ventilation systems, WIP/V-M fire dampers are used in mixed systems, combining both fire and comfort ventilation systems. The devices prevent fire, smoke and fire gases propagation to the adjacent areas. During normal operation, the fire damper is in open or closed position depending on its function. In the fire-covered area, the fire damper is open, whereas it remains closed in the other areas. WIP/V, WIP/V-M fire dampers due to their design are intended for use in systems, where the components such as a silencer, bend or supply/return grille are installed downstream of the fire damper.

2. Design

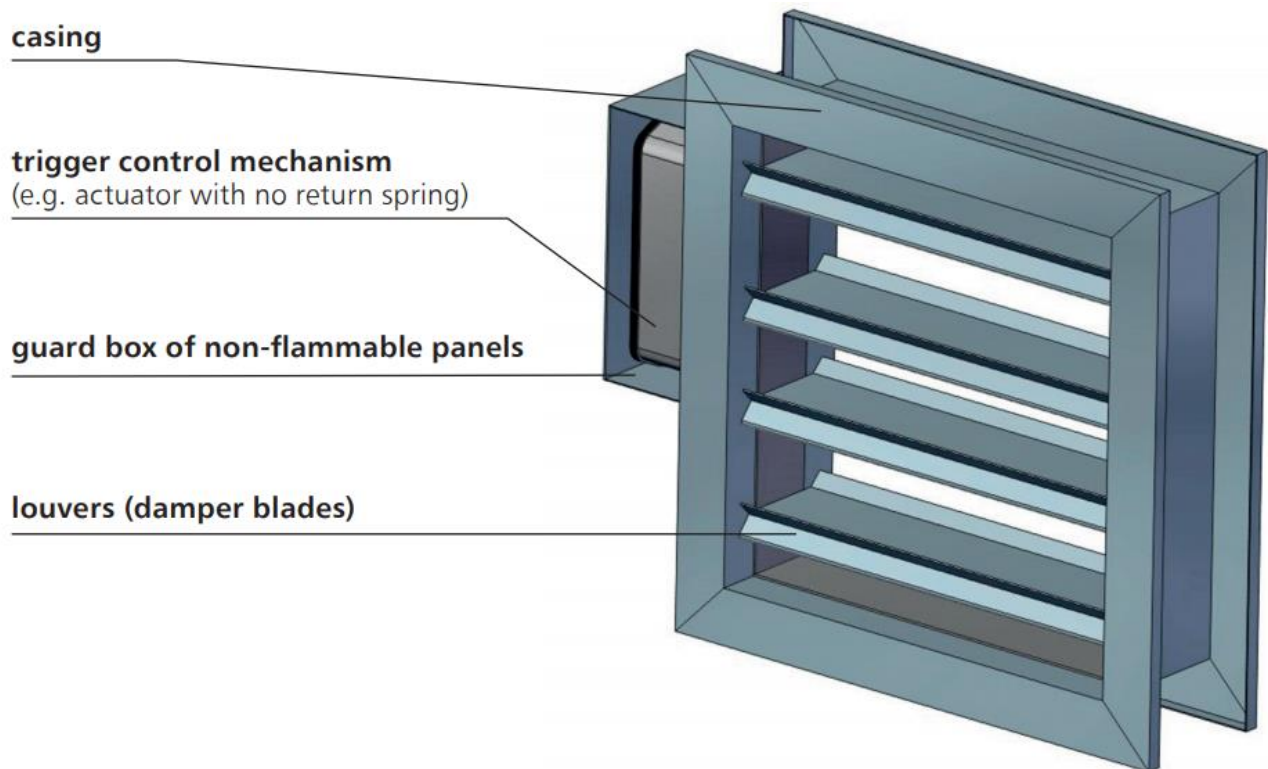

WIP/V, WIP/V-M fire dampers consist of a rectangular casing, movable multiple blades rotating around their axis and a remote trigger control mechanism. Damper casing is made of galvanised or stainless steel sheet. Its integral part is a flange of silicate-cement panels. An intumescent seal and the ventilation seals are installed on the inside to ensure air tightness. The damper casing total length is 140 mm.

The louver surface (blades) is covered with galvanised or stainless steel sheet. Each louver with the thickness of 15 mm is filled with a plaster panel. The damper blades revolve on their axes, which consist of two steel pins.

Square and rectangular dampers are made with 50 mm flanges that enable the correct installation of dampers in ventilation ducts. In a circular duct, the damper is made as square with a circular connection.

3. Versions

3.1 WIP/V, WIP/V-M – smoke exhaust fire dampers for multi-zone fire ventilation systems with an actuator – damper closing and opening with an actuator

During normal operation, the fire dampers are opened or closed. In case of fire, the fire damper louvers are opened in the fire-covered area and closed in the other areas - the fire damper is released remotely by feeding the supply voltage to the trigger control mechanism.

WIP/V, WIP/V-M fire dampers are equipped with a Belimo trigger control mechanisms **BLE**, **BE** axial actuator without the return spring (24 V AC/DC or 230 V AC). BLE, BE series actuators are equipped with limit switches used to monitor the damper blade position. Furthermore, the mechanical position indicator is placed on the actuator.

Fire dampers with Belimo BLE, BE actuators can be opened/closed by supplying voltage to the actuator terminals. Furthermore, dampers with those actuators may be opened/closed manually using a key.

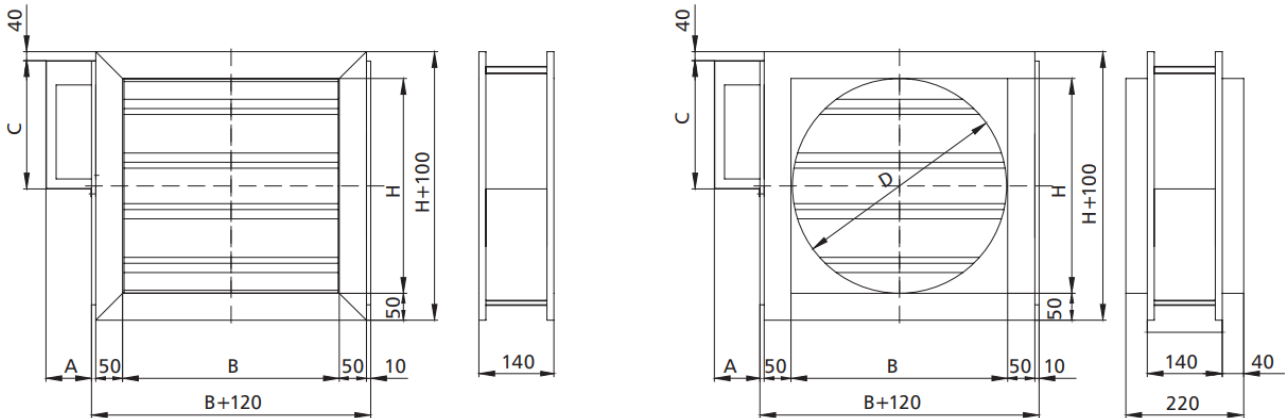

Mechanism	A	C
BLE	125	275
BE	125	325

4. Dimensions

Rectangular dampers:

- Nominal width B: from 120 mm to 1000 mm
- Nominal height H: from 160 mm to 1000 mm
- The maximum cross-section surface of one damper up to 1 m²

Apart from the standard dimensions, fire dampers may be manufactured with intermediate dimensions (in 1 mm increments, in the given range).

Square fire dampers may also be fitted with round connectors for the spigot connection to the round ducts.

5. Installation

Rectangular WIP/V, WIP/V-M fire dampers are class EI120(V_{ed} i↔o)₁₀₀₀C10000AAmulti devices, if installed in a concrete partition, min. 110 mm thick made of full bricks or cellular concrete blocks, min. thickness 115 mm.

5.1 Preparation of installation openings

The minimum dimensions of the installation opening that permits correct installation of the WIP/V, WIP/V-M damper are:

$$B_o = (A+Bz+80) \text{ mm}$$

$$H_o = (H+180) \text{ mm}$$

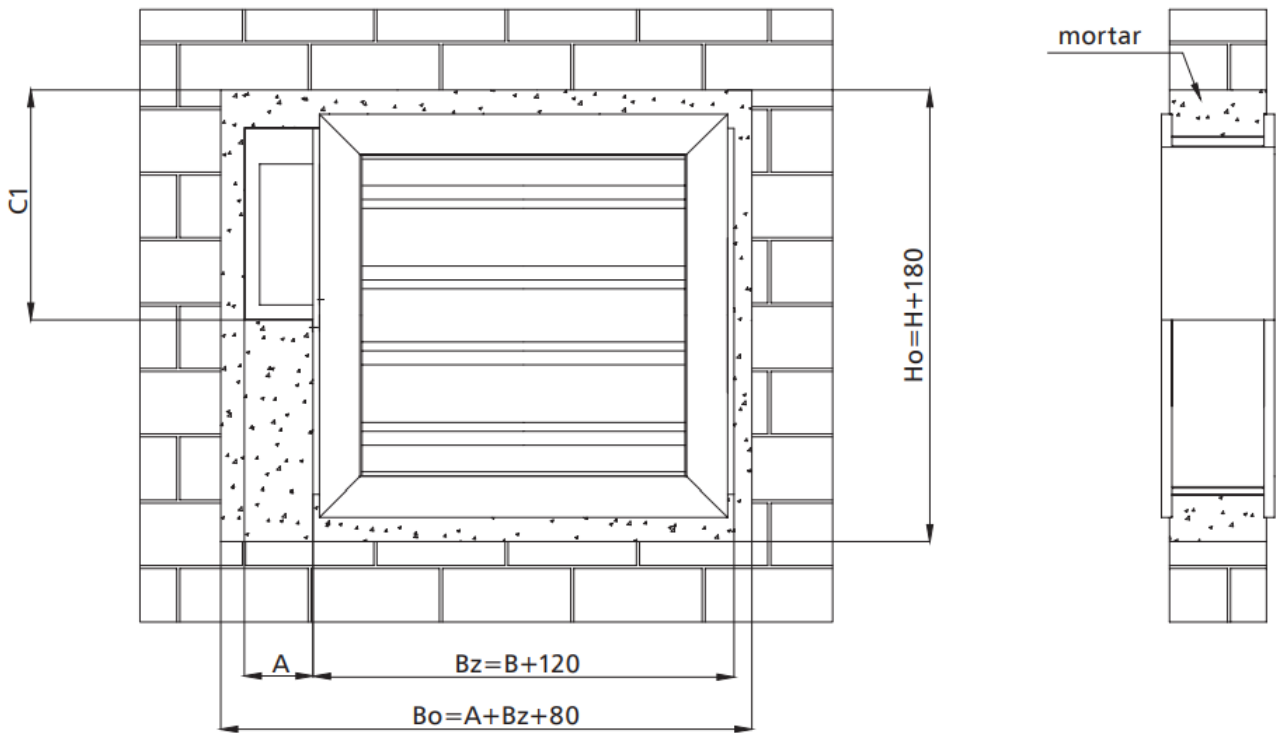

	BE	BLE
C1 [mm]	385	335
A [mm]	125	125

5.2 Sample installation in concrete or masonry walls

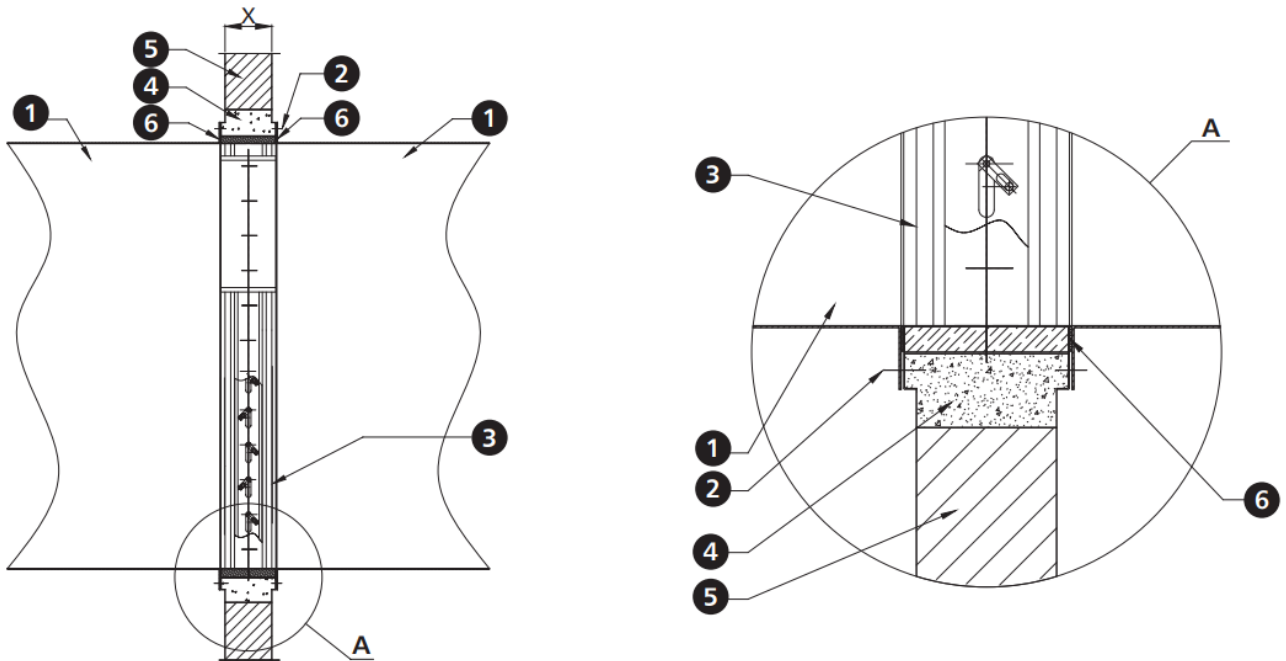

1. Smoke ventilation duct
2. ST4.2x16 screw
3. Fire damper WIP

4. Sealing e.g. masonry cement, mortar*
5. Masonry wall

6. Heat resistant gasket
- X. Wall thickness

i It is possible to use a different sealing which ensures the required fire resistance

5.3 Sample installation in concrete block or full brick walls

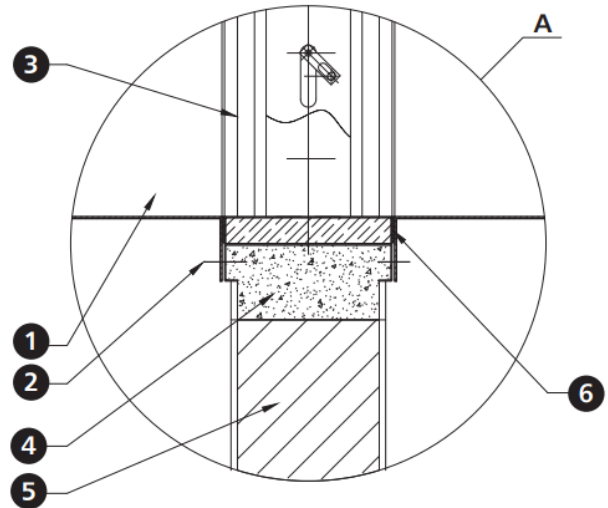
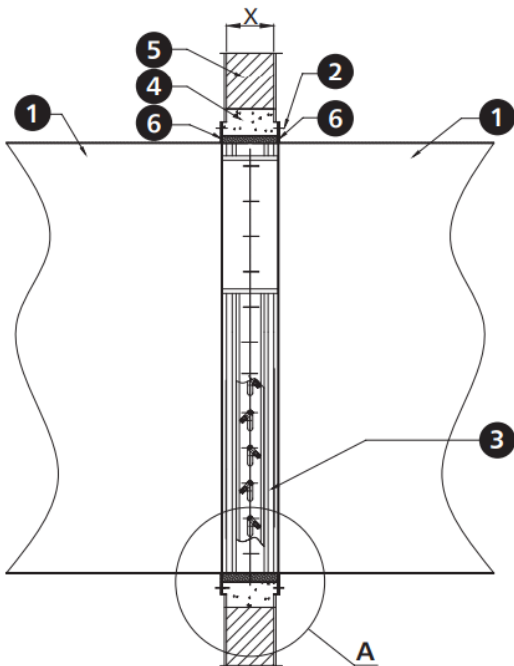

1. Smoke ventilation duct
2. ST4.2x16
3. Fire damper WIP
4. Sealing – cement masonry mortar*
5. Wall of concrete blocks or full bricks
6. Heat resistant gasket
- X. Wall thickness

i It is possible to use a different sealing which ensures the required fire resistance

5.4 Sample installation in ceiling

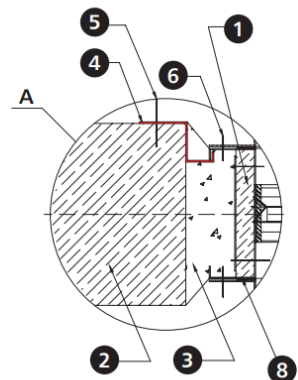
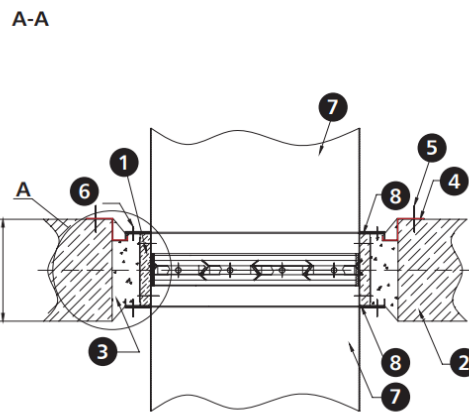
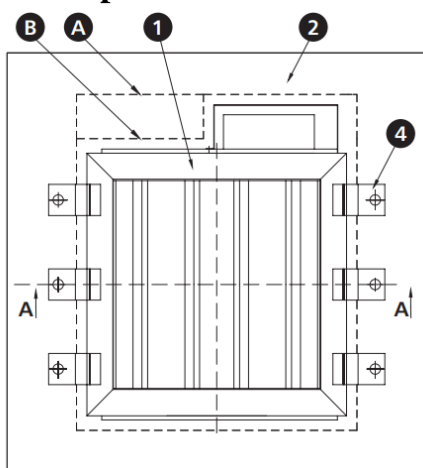

1. Fire damper WIP
2. Ceiling
3. E.g. cement mortar*

4. Mounting bracket
5. Steel expansion anchor with m6 metal screw
6. ST4.2x16 screw

7. Ventilation duct
8. Heat resistant gasket
- A./B. construction opening

i It is possible to use a different sealing which ensures the required fire resistance

5.5 Sample installation outside the fire partition

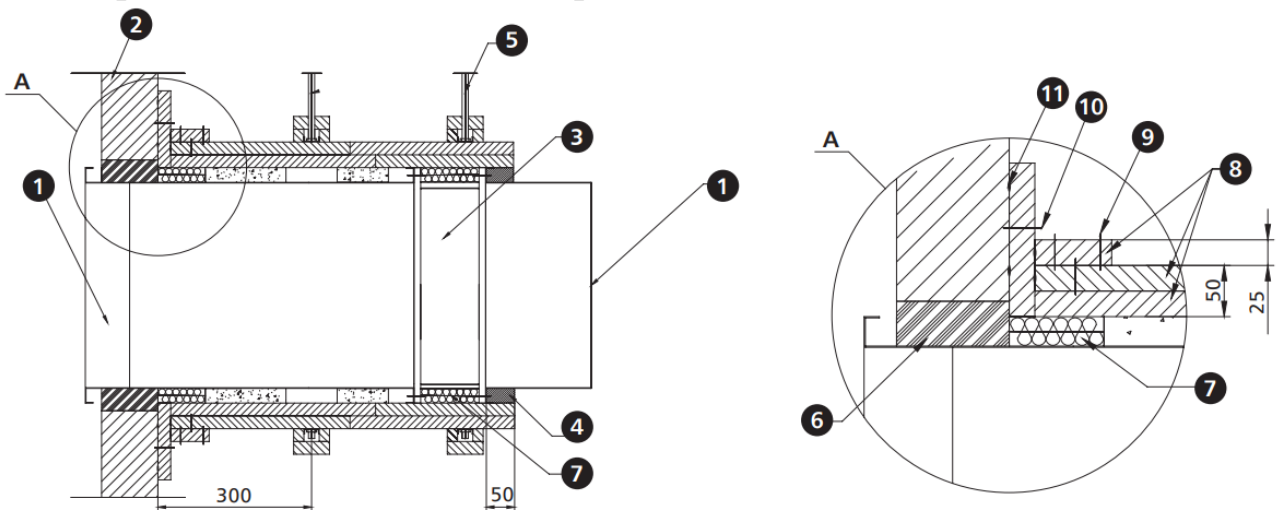

- | | | |
|---------------------|---|---|
| 1. Ventilation duct | 6. Sealing (cement or cement-lime masonry mortar)* | 9. Screws 3.5 x 50 spacing: ~150 mm |
| 2. Partition | 7. Mineral wool with the density of at least 80kg/m ³ , A1 class | 10. Steel expansion anchor Ø8 x 80 mm |
| 3. Fire damper WIP | 8. Ridurit fire retardant board | 11. Board joint sealed with Conlit Glue |
| 4. Gypsum filling | | |
| 5. Duct suspension | | |

5.6 Sample installation in a multiple set (a battery of four dampers)

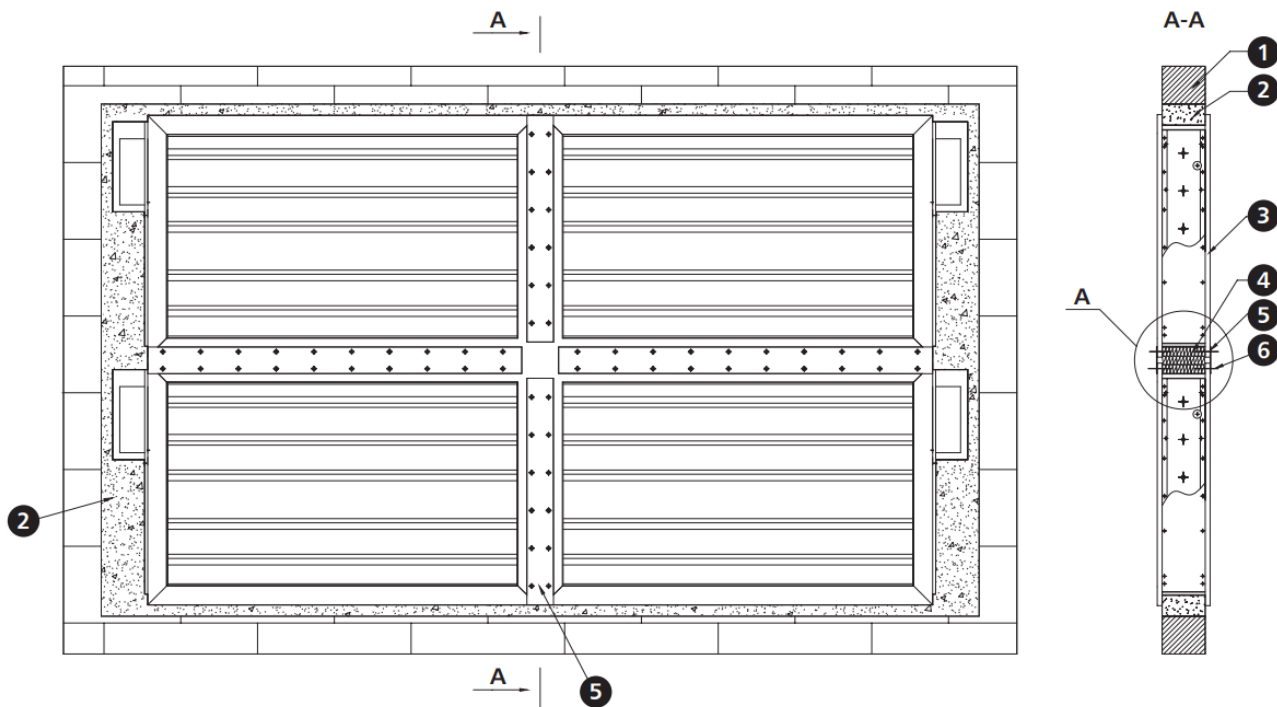

1. e.g. masonry wall
2. e.g. cement mortar*
3. fire damper WIP
4. mineral wool with the density of at least 80 kg/m³, A1 class
5. Installation flat bar with the width of 70 mm
6. ST8x16 screw

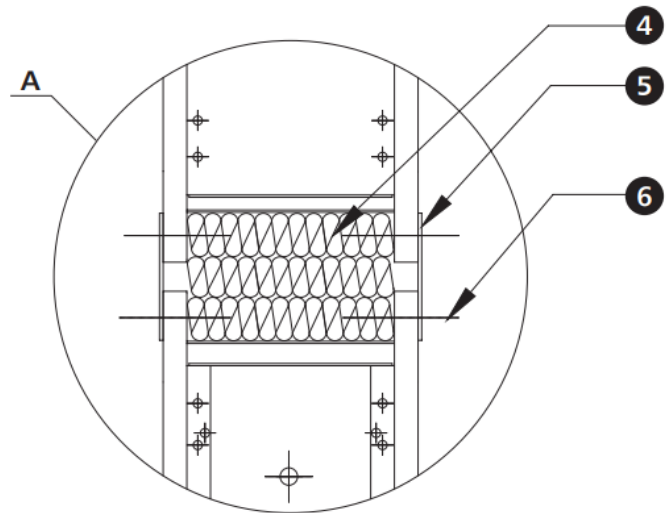

5.7 Fire damper installation with vertical rotation axis of the louvers

The fire damper can operate with a vertical axis of louver rotation with the top or bottom-mounted mechanism.

5.8 Distance between systems and partitions

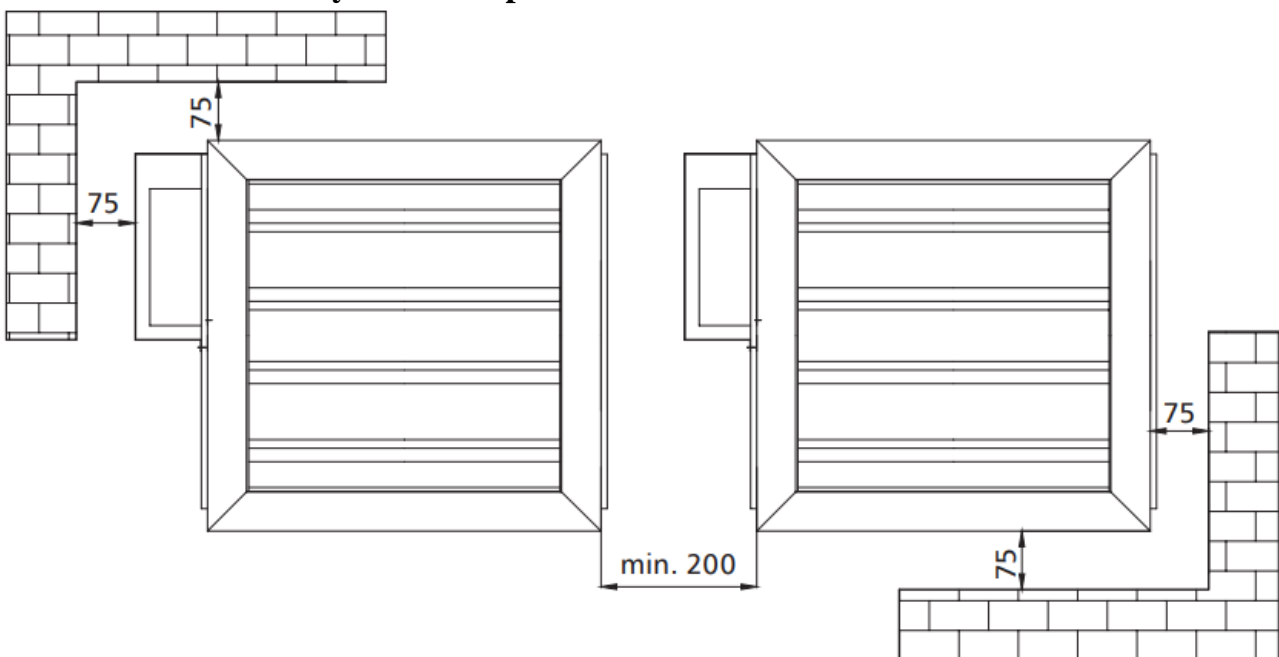

5.9 Example applications – installation with masking cover

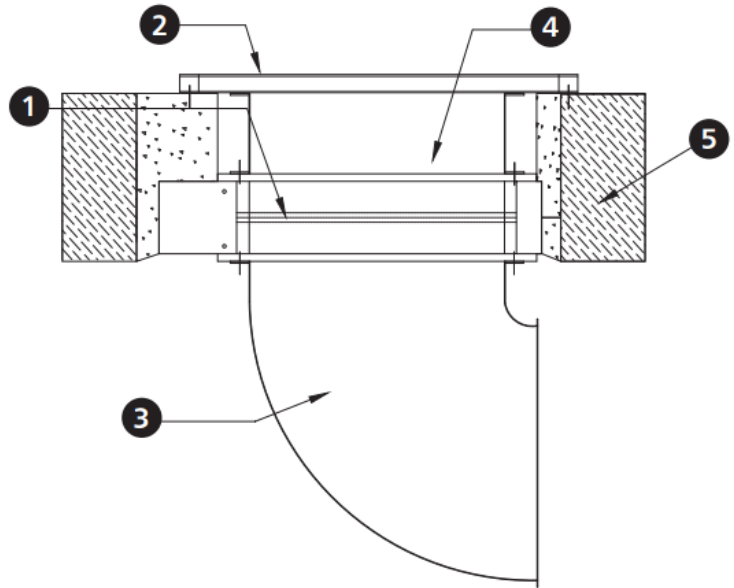

- 1. Fire damper WIP
- 2. masking cover
- 3. ventilation duct
- 4. duct – ventilation straight connection pipe
- 5. wall, ceiling

If a WIP/V, WIP/V-M damper is used, thanks to the louvers (no single-plane partition) it is possible to use the space in front of and behind the damper for such system elements as a duct cover or a rectangular silencer or to route a duct along the wall using a duct bend or reduction.

6. Technical parameters of WIP/V, WIP/V-M rectangular dampers

B – nominal width [mm]

v – velocity [m/s]

Q – flow [m³/h]

H – nominal height [mm]

Sk – duct cross section [m²]

Dp – pressure drop [Pa]

Se – damper active cross section [m²]

L_{WA} – damper noise level [dB]

		height H [mm]															
		200					250					300					
		v [m/s]	Sk [m ²]	Se [m ²]	Q [m ³ /h]	dp [Pa]	L _{WA} [dB]	Sk [m ²]	Se [m ²]	Q [m ³ /h]	dp [Pa]	L _{WA} [dB]	Sk [m ²]	Se [m ²]	Q [m ³ /h]	dp [Pa]	L _{WA} [dB]
width B [mm]	200	4	0.040	0.034	490	6	26	0.050	0.043	612	6	26	0.06	0.051	734	6	27
		6			734	13	36			918	13	37			1102	13	37
		8			979	24	44			1224	23	44			1469	22	45
		10			1224	37	49			1530	36	50			1836	35	50
	250	4	0.050	0.043	612	6	26	0.063	0.053	765	6	27	0.075	0.064	918	6	28
		6			918	13	37			1148	13	38			1377	13	38
		8			1224	23	44			1530	23	45			1836	22	46
		10			1530	36	50			1913	36	51			2295	35	51
	300	4	0.060	0.051	734	6	27	0.075	0.064	918	6	28	0.09	0.077	1102	6	28
		6			1102	13	37			1377	13	38			1652	13	39
		8			1469	23	45			1836	23	46			2203	22	46
		10			1836	36	51			2295	36	52			2754	35	52
	350	4	0.070	0.060	857	6	27	0.088	0.074	1071	6	29	0.105	0.089	1285	5	29
		6			1285	13	38			1607	13	39			1928	12	39
		8			1714	22	45			2142	22	46			2570	22	47
		10			2142	35	51			2678	35	52			3213	34	52
	400	4	0.080	0.068	979	6	28	0.100	0.085	1224	6	29	0.12	0.102	1469	5	29
		6			1469	13	38			1836	13	39			2203	12	40
		8			1958	22	46			2448	22	47			2938	22	47
		10			2448	35	52			3060	35	53			3672	34	53
	450	4	0.090	0.077	1102	6	28	0.113	0.096	1377	6	29	0.135	0.115	1652	5	30
		6			1652	13	39			2066	13	40			2479	12	40
		8			2203	22	46			2754	22	47			3305	22	48
		10			2754	35	52			3443	35	53			4131	34	54
	500	4	0.100	0.085	1224	5	28	0.125	0.106	1530	5	29	0.15	0.128	1836	5	30
		6			1836	12	39			2295	12	40			2754	12	40
		8			2448	22	46			3060	22	47			3672	21	48
		10			3060	34	52			3825	34	53			4590	33	54
	550	4	0.110	0.094	1346	5	29	0.138	0.117	1683	5	30	0.165	0.140	2020	5	31
		6			2020	12	39			2525	12	40			3029	12	41
		8			2693	22	47			3366	22	48			4039	22	49
		10			3366	34	53			4208	34	54			5049	34	54
	600	4	0.120	0.102	1469	5	29	0.150	0.128	1836	5	30	0.18	0.153	2203	5	31
		6			2203	12	40			2754	12	41			3305	12	41
		8			2938	22	47			3672	22	48			4406	21	49
		10			3672	34	53			4590	34	54			5508	33	54
	650	4	0.130	0.111	1591	5	30	0.163	0.138	1989	5	30	0.195	0.166	2387	5	31
		6			2387	12	40			2984	12	41			3580	12	41
		8			3182	22	48			3978	22	49			4774	21	49
		10			3978	34	53			4973	34	54			5967	33	55
	700	4	0.140	0.119	1714	5	30	0.175	0.149	2142	5	31	0.21	0.179	2570	5	31
		6			2570	12	40			3213	12	41			3856	12	42
		8			3427	22	48			4284	22	49			5141	21	49
		10			4284	34	54			5355	34	55			6426	33	55
	750	4	0.150	0.128	1836	5	30	0.188	0.159	2295	5	31	0.225	0.191	2754	5	31
		6			2754	12	40			3443	12	41			4131	12	42
		8			3672	21	48			4590	21	49			5508	21	49
		10			4590	33	54			5738	33	55			6885	32	55
	800	4	0.160	0.136	1958	5	30	0.200	0.170	2448	5	31	0.24	0.204	2938	5	31
		6			2938	12	41			3672	12	42			4406	12	42
		8			3917	21	48			4896	21	49			5875	21	49
		10			4896	33	54			6120	33	55			7344	32	55
	850	4	0.170	0.145	2081	5	30	0.213	0.181	2601	5	31	0.255	0.217	3121	5	31
		6			3121	12	40			3902	12	41			4682	11	42
		8			4162	21	48			5202	21	49			6242	20	49
		10			5202	32	54			6503	32	55			7803	31	55
	900	4	0.180	0.153	2203	5	30	0.225	0.191	2754	5	31	0.27	0.230	3305	5	31
		6			3305	12	41			4131	12	42			4957	11	42
		8			4406	21	48			5508	21	49			6610	20	50
		10			5508	32	54			6885	32	55			8262	31	55
	1000	4	0.200	0.170	2448	5	31	0.250	0.213	3060	5	32	0.3	0.255	3672	5	32
		6			3672	12	41			4590	12	42			5508	11	43
		8			4896	21	49			6120	21	50			7344	20	50
		10			6120	32	54			7650	32	55			9180	31	56

B – nominal width [mm]
H – nominal height [mm]

v – velocity [m/s]
Sk – duct cross section [m²]
Se – damper active cross section [m²]

Q – flow [m³/h]
Dp – pressure drop [Pa]
L_{WA} – damper noise level [dB]

		height H [mm]															
		350					400					450					
		v [m/s]	Sk [m ²]	Se [m ²]	Q [m ³ /h]	dp [Pa]	L _{WA} [dB]	Sk [m ²]	Se [m ²]	Q [m ³ /h]	dp [Pa]	L _{WA} [dB]	Sk [m ²]	Se [m ²]	Q [m ³ /h]	dp [Pa]	L _{WA} [dB]
width B [mm]	200	4	0.070	0.060	857	6	27	0.080	0.068	979	5	27	0.090	0.077	1 102	5	28
		6			1 285	13	38			1 469	12	38			1 652	12	38
		8			1 714	22	45			1 958	22	45			2 203	22	46
		10			2 142	35	51			2 448	34	51			2 754	34	52
	250	4	0.088	0.074	1 071	6	28	0.100	0.085	1 224	5	28	0.113	0.096	1 377	5	29
		6			1 607	13	39			1 836	12	39			2 066	12	39
		8			2 142	22	46			2 448	22	46			2 754	22	47
		10			2 678	35	52			3 060	34	52			3 443	34	53
	300	4	0.105	0.089	1 285	6	29	0.120	0.102	1 469	5	29	0.135	0.115	1 652	5	30
		6			1 928	13	40			2 203	12	40			2 479	12	40
		8			2 570	22	47			2 938	22	47			3 305	22	48
		10			3 213	35	53			3 672	34	53			4 131	34	54
	350	4	0.123	0.104	1 499	5	29	0.140	0.119	1 714	5	29	0.158	0.134	1 928	5	30
		6			2 249	12	40			2 570	12	40			2 892	12	41
		8			2 999	22	47			3 427	21	48			3 856	21	48
		10			3 749	34	53			4 284	33	53			4 820	33	54
	400	4	0.140	0.119	1 714	5	30	0.160	0.136	1 958	5	30	0.180	0.153	2 203	5	31
		6			2 570	12	40			2 938	12	41			3 305	12	41
		8			3 427	22	48			3 917	21	48			4 406	21	49
		10			4 284	34	54			4 896	33	54			5 508	33	54
	450	4	0.158	0.134	1 928	5	30	0.180	0.153	2 203	5	31	0.203	0.172	2 479	5	31
		6			2 892	12	41			3 305	12	41			3 718	12	42
		8			3 856	22	48			4 406	21	49			4 957	21	49
		10			4 820	34	54			5 508	33	54			6 197	33	55
	500	4	0.175	0.149	2 142	5	30	0.200	0.170	2 448	5	31	0.225	0.191	2 754	5	32
		6			3 213	12	41			3 672	12	42			4 131	12	42
		8			4 284	21	48			4 896	21	49			5 508	21	50
		10			5 355	33	54			6 120	33	55			6 885	33	55
	550	4	0.193	0.164	2 570	5	31	0.220	0.187	2 693	5	31	0.248	0.210	3 029	5	32
		6			3 856	12	42			4 039	12	42			4 544	12	43
		8			5 141	22	49			5 386	21	49			6 059	21	50
		10			6 426	34	55			6 732	33	55			7 574	33	56
	600	4	0.210	0.179	2 570	5	31	0.240	0.204	2 938	4	28	0.270	0.230	3 305	5	32
		6			3 856	12	42			4 406	8	37			4 957	12	42
		8			5 141	21	49			5 875	14	44			6 610	21	50
		10			6 426	33	55			7 344	32	55			8 262	32	56
	650	4	0.228	0.193	2 785	5	32	0.260	0.221	3 182	5	32	0.293	0.249	3 580	5	32
		6			4 177	12	42			4 774	12	42			5 370	12	43
		8			5 569	21	50			6 365	21	50			7 160	21	50
		10			6 962	33	55			7 956	32	56			8 951	32	56
	700	4	0.245	0.208	2 999	5	32	0.28	0.238	3 427	5	32	0.315	0.268	3 856	5	33
		6			4 498	12	42			5 141	12	43			5 783	12	43
		8			5 998	21	50			6 854	21	50			7 711	21	51
		10			7 497	33	56			8 568	32	56			9 639	32	56
	750	4	0.263	0.223	3 213	5	32	0.3	0.255	3 672	5	32	0.338	0.287	4 131	5	33
		6			4 820	12	42			5 508	12	43			6 197	12	43
		8			6 426	21	50			7 344	21	50			8 262	21	51
		10			8 033	32	56			9 180	32	56			10 328	32	57
	800	4	0.280	0.238	3 427	5	32	0.32	0.272	3 917	5	33	0.360	0.306	4 406	5	32
		6			5 141	12	43			5 875	11	43			6 610	11	42
		8			6 854	21	50			7 834	20	50			8 813	20	50
		10			8 568	32	56			9 792	31	56			11 016	31	56
	850	4	0.298	0.253	3 641	5	32	0.34	0.289	4 162	5	32	0.383	0.325	4 682	5	31
		6			5 462	11	42			6 242	11	43			7 023	11	42
		8			7 283	20	50			8 323	19	50			9 364	19	49
		10			9 104	31	56			10 404	30	56			11 705	30	55
	900	4	0.315	0.268	3 856	5	32	0.360	0.306	4 406	6	35	0.405	0.344	4 957	5	31
		6			5 783	11	43			6 610	12	44			7 436	11	42
		8			7 711	20	50			8 813	26	54			9 914	19	49
		10			9 639	31	56			11 016	30	56			12 393	30	55
	1000	4	0.350	0.298	4 284	5	33	0.400	0.340	4 896	5	33	0.450	0.383	5 508	5	31
		6			6 426	11	43			7 344	11	43			8 262	11	42
		8			8 568	20	51			9 792	19	51			11 016	19	49
		10			10 710	31	56			12 240	30	57			13 770	30	55

B – nominal width [mm]
H – nominal height [mm]

v – velocity [m/s]
Sk – duct cross section [m²]
Se – damper active cross section [m²]

Q – flow [m³/h]
Dp – pressure drop [Pa]
L_{WA} – damper noise level [dB]

		height H [mm]															
		500					550					600					
		v [m/s]	Sk [m ²]	Se [m ²]	Q [m ³ /h]	dp [Pa]	L _{WA} [dB]	Sk [m ²]	Se [m ²]	Q [m ³ /h]	dp [Pa]	L _{WA} [dB]	Sk [m ²]	Se [m ²]	Q [m ³ /h]	dp [Pa]	L _{WA} [dB]
width B [mm]	200	4	0.100	0.085	1 224	5	28	0.110	0.094	1 346	5	28	0.120	0.102	1 469	5	28
		6			1 836	12	39			2 020	12	39			2 203	12	39
		8			2 448	21	46			2 693	21	46			2 938	21	46
		10			3 060	33	52			3 366	33	52			3 672	32	52
	250	4	0.125	0.106	1 530	5	29	0.138	0.117	1 683	5	29	0.150	0.128	1 836	5	29
		6			2 295	12	40			2 525	12	40			2 754	12	40
		8			3 060	21	47			3 366	21	47			3 672	21	47
		10			3 825	33	53			4 208	33	53			4 590	32	53
	300	4	0.150	0.128	1 836	5	30	0.165	0.140	2 020	5	30	0.180	0.153	2 203	5	30
		6			2 754	12	40			3 029	12	41			3 305	12	41
		8			3 672	21	48			4 039	21	48			4 406	21	48
		10			4 590	33	54			5 049	33	54			5 508	32	54
350	4	0.175	0.149	2 142	5	30	0.193	0.164	2 356	5	30	0.210	0.179	2 570	5	30	
	6			3 213	12	41			3 534	12	41			3 856	11	41	
	8			4 284	21	48			4 712	21	49			5 141	20	48	
	10			5 355	32	54			5 891	32	54			6 426	31	54	
400	4	0.200	0.170	2 448	5	31	0.220	0.187	2 693	5	31	0.240	0.204	2 938	5	31	
	6			3 672	12	41			4 039	12	42			4 406	11	42	
	8			4 896	21	49			5 386	21	49			5 875	20	49	
	10			6 120	32	54			6 732	32	55			7 344	31	55	
450	4	0.225	0.191	2 754	5	31	0.248	0.210	3 029	5	32	0.270	0.230	3 305	5	31	
	6			4 131	12	42			4 544	12	42			4 957	11	42	
	8			5 508	21	49			6 059	21	50			6 610	20	50	
	10			6 885	32	55			7 574	32	55			8 262	31	55	
500	4	0.250	0.213	3 060	5	31	0.275	0.234	3 366	5	32	0.300	0.255	3 672	5	32	
	6			4 590	11	42			5 049	12	43			5 508	11	43	
	8			6 120	22	51			6 732	21	50			7 344	20	50	
	10			7 650	32	55			8 415	32	56			9 180	31	56	
550	4	0.275	0.234	3 672	5	32	0.303	0.257	4 039	5	32	0.330	0.281	4 406	5	32	
	6			5 508	12	43			6 059	12	43			6 610	11	43	
	8			7 344	21	50			8 078	21	50			8 813	20	50	
	10			9 180	32	56			10 098	32	56			11 016	31	56	
600	4	0.300	0.255	3 672	5	32	0.330	0.281	4 039	5	32	0.360	0.306	4 406	5	32	
	6			5 508	11	43			6 059	11	43			6 610	11	43	
	8			7 344	20	50			8 078	20	50			8 813	19	50	
	10			9 180	31	56			10 098	31	56			11 016	30	56	
650	4	0.325	0.276	3 978	5	33	0.358	0.304	4 376	5	33	0.390	0.332	4 774	5	33	
	6			5 967	12	43			6 564	11	43			7 160	11	43	
	8			7 956	21	51			8 752	20	51			9 547	19	51	
	10			9 945	31	56			10 940	31	57			11 934	30	57	
700	4	0.350	0.298	4 284	5	33	0.385	0.327	4 712	5	33	0.420	0.357	5 141	5	33	
	6			6 426	11	43			7 069	11	44			7 711	11	44	
	8			8 568	20	51			9 425	20	51			10 282	19	51	
	10			10 710	31	56			11 781	31	57			12 852	30	57	
750	4	0.375	0.319	4 590	5	33	0.413	0.351	5 049	5	33	0.450	0.383	5 508	5	33	
	6			6 885	11	43			7 574	11	44			8 262	11	44	
	8			9 180	20	51			10 098	20	51			11 016	19	51	
	10			11 475	31	57			12 623	31	57			13 770	30	57	
800	4	0.400	0.340	4 896	5	32	0.440	0.374	5 386	5	33	0.480	0.408	5 875	5	33	
	6			7 344	11	43			8 078	11	44			8 813	10	44	
	8			9 792	19	51			10 771	19	51			11 750	19	51	
	10			12 240	30	56			13 464	30	57			14 688	29	57	
850	4	0.425	0.361	5 202	5	32	0.468	0.397	5 722	5	33	0.510	0.434	6 242	4	33	
	6			7 803	10	43			8 583	10	44			9 364	10	43	
	8			10 404	19	50			11 444	19	51			12 485	18	51	
	10			13 005	29	56			14 306	29	57			15 606	28	57	
900	4	0.450	0.383	5 508	5	32	0.495	0.421	6 059	5	33	0.540	0.459	6 610	4	33	
	6			8 262	10	43			9 088	10	44			9 914	10	41	
	8			11 016	19	50			12 118	19	51			13 219	18	49	
	10			13 770	29	56			15 147	29	57			16 524	28	54	
1000	4	0.500	0.425	6 120	5	32	0.550	0.468	6 059	5	34	0.600	0.510	7 344	4	34	
	6			9 180	10	43			9 088	10	44			11 016	10	44	
	8			12 240	19	50			12 118	19	52			14 688	18	52	
	10			15 300	29	56			15 147	29	58			18 360	28	57	

B – nominal width [mm]
H – nominal height [mm]

v – velocity [m/s]
Sk – duct cross section [m²]
Se – damper active cross section [m²]

Q – flow [m³/h]
Dp – pressure drop [Pa]
L_{WA} – damper noise level [dB]

		height H [mm]															
		650					700					750					
		v [m/s]	Sk [m ²]	Se [m ²]	Q [m ³ /h]	dp [Pa]	L _{WA} [dB]	Sk [m ²]	Se [m ²]	Q [m ³ /h]	dp [Pa]	L _{WA} [dB]	Sk [m ²]	Se [m ²]	Q [m ³ /h]	dp [Pa]	L _{WA} [dB]
width B [mm]	200	4	0.130	0.111	1 591	5	29	0.140	0.119	1 714	5	29	0.150	0.128	1 836	5	29
		6			2 387	12	39			2 570	11	39			2 754	11	40
		8			3 182	21	47			3 427	20	47			3 672	20	47
		10			3 978	32	53			4 284	31	52			4 590	31	53
	250	4	0.163	0.138	1 989	5	30	0.175	0.149	2 142	5	30	0.188	0.159	2 295	5	30
		6			2 984	12	40			3 213	11	40			3 443	11	40
		8			3 978	21	48			4 284	20	48			4 590	20	48
		10			4 973	32	54			5 355	31	53			5 738	31	54
	300	4	0.195	0.166	2 387	5	30	0.210	0.179	2 570	5	30	0.225	0.191	2 754	5	31
		6			3 580	12	41			3 856	11	41			4 131	11	41
		8			4 774	21	49			5 141	20	48			5 508	20	49
		10			5 967	32	54			6 426	31	54			6 885	31	55
350	4	0.228	0.193	2 785	5	31	0.245	0.208	2 999	5	31	0.263	0.223	3 213	5	31	
	6			4 177	11	41			4 498	11	41			4 820	11	42	
	8			5 569	20	49			5 998	19	49			6 426	19	49	
	10			6 962	31	55			7 497	30	54			8 033	30	55	
400	4	0.260	0.221	3 182	5	31	0.280	0.238	3 427	5	31	0.300	0.255	3 672	5	32	
	6			4 774	11	42			5 141	11	42			5 508	11	42	
	8			6 365	20	49			6 854	19	49			7 344	19	50	
	10			7 956	31	55			8 568	30	55			9 180	30	55	
450	4	0.293	0.249	3 580	5	32	0.315	0.268	3 856	5	32	0.338	0.287	4 131	5	32	
	6			5 370	11	42			5 783	11	42			6 197	11	43	
	8			7 160	20	50			7 711	19	50			8 262	19	50	
	10			8 951	31	56			9 639	30	56			10 328	30	56	
500	4	0.325	0.276	3 978	5	32	0.350	0.298	4 284	5	32	0.375	0.319	4 590	5	32	
	6			5 967	11	43			6 426	11	43			6 885	11	43	
	8			7 956	20	50			8 568	19	50			9 180	19	51	
	10			9 945	31	56			10 710	30	56			11 475	30	56	
550	4	0.358	0.304	4 774	5	33	0.385	0.327	4 712	5	33	0.413	0.351	5 049	5	33	
	6			7 160	11	43			7 069	11	43			7 574	11	43	
	8			9 547	20	51			9 425	19	51			10 098	19	51	
	10			11 934	31	57			11 781	30	56			12 623	30	57	
600	4	0.390	0.332	4 774	5	33	0.420	0.357	5 141	5	33	0.450	0.383	5 508	5	33	
	6			7 160	11	44			7 711	11	44			8 262	11	44	
	8			9 547	20	51			10 282	19	51			11 016	19	51	
	10			11 934	31	57			12 852	30	57			13 770	30	57	
650	4	0.423	0.359	5 171	5	33	0.455	0.387	5 569	5	33	0.488	0.414	5 967	5	33	
	6			7 757	11	44			8 354	10	43			8 951	10	44	
	8			10 343	19	51			11 138	19	51			11 934	19	51	
	10			12 929	30	57			13 923	29	57			14 918	29	57	
700	4	0.455	0.387	5 569	5	33	0.490	0.417	5 998	5	33	0.525	0.446	6 426	5	34	
	6			8 354	11	44			8 996	10	44			9 639	10	44	
	8			11 138	19	51			11 995	19	51			12 852	19	52	
	10			13 923	30	57			14 994	29	57			16 065	29	57	
750	4	0.488	0.414	5 967	5	34	0.525	0.446	6 426	5	34	0.563	0.478	6 885	5	34	
	6			8 951	11	44			9 639	10	44			10 328	10	44	
	8			11 934	19	52			12 852	19	52			13 770	19	52	
	10			14 918	30	57			16 065	29	57			17 213	29	58	
800	4	0.520	0.442	6 365	5	33	0.560	0.476	6 854	4	29	0.600	0.510	7 344	4	34	
	6			9 547	10	44			10 282	7	37			11 016	10	44	
	8			12 730	19	51			13 709	11	43			14 688	18	52	
	10			15 912	29	57			17 136	28	54			18 360	28	57	
850	4	0.553	0.470	6 763	4	33	0.595	0.506	7 283	4	34	0.638	0.542	7 803	4	34	
	6			10 144	10	43			10 924	10	44			11 705	10	44	
	8			13 525	18	51			14 566	18	52			15 606	18	52	
	10			16 907	28	57			18 207	28	57			19 508	28	58	
900	4	0.585	0.497	7 160	4	33	0.630	0.536	7 711	4	33	0.675	0.574	8 262	4	34	
	6			10 741	10	43			11 567	10	44			12 393	10	44	
	8			14 321	18	51			15 422	17	51			16 524	17	52	
	10			17 901	28	57			19 278	27	57			20 655	27	58	
1000	4	0.650	0.553	7 956	4	33	0.700	0.595	8 568	4	34	0.750	0.638	9 180	4	34	
	6			11 934	10	43			12 852	10	44			13 770	10	45	
	8			15 912	18	51			17 136	17	52			18 360	17	52	
	10			19 890	28	57			21 420	27	58			22 950	27	58	

B – nominal width [mm]
H – nominal height [mm]

v – velocity [m/s]
Sk – duct cross section [m²]
Se – damper active cross section [m²]

Q – flow [m³/h]
Dp – pressure drop [Pa]
L_{WA} – damper noise level [dB]

		height H [mm]																							
		800						850						900						1000					
		v [m/s]	Sk [m ²]	Se [m ²]	Q [m ³ /h]	dp [Pa]	L _{WA} [dB]	Sk [m ²]	Se [m ²]	Q [m ³ /h]	dp [Pa]	L _{WA} [dB]	Sk [m ²]	Se [m ²]	Q [m ³ /h]	dp [Pa]	L _{WA} [dB]	Sk [m ²]	Se [m ²]	Q [m ³ /h]	dp [Pa]	L _{WA} [dB]			
width B [mm]	200	4	0.160	0.136	1 958	5	29	0.170	0.145	2 081	5	29	0.180	0.153	2 203	5	29	0.200	0.170	2 448	5	29			
		6			2 938	11	39			3 121	11	40			3 305	10	39			3 672	10	40			
		8			3 917	19	47			4 162	19	47			4 406	19	47			4 896	19	47			
				4 896	30	53			5 202	30	53			5 508	29	53			6 120	29	53				
				2 448	5	30			2 601	5	30			2 754	5	30			3 060	5	30				
				3 672	11	40			3 902	11	41			4 131	10	40			4 590	10	41				
				4 896	19	48			5 202	19	48			5 508	19	48			6 120	19	48				
				6 120	30	54			6 503	30	54			6 885	29	54			7 650	29	54				
				2 938	5	31			3 121	5	31			3 305	5	31			3 672	5	31				
				4 406	11	41			4 682	11	41			4 957	10	41			5 508	10	42				
				5 875	19	49			6 242	19	49			6 610	19	49			7 344	19	49				
				7 344	30	54			7 803	30	55			8 262	29	54			9 180	29	55				
			3 427	5	31			3 641	5	31			3 856	4	31			4 284	4	31					
			5 141	10	41			5 462	10	42			5 783	10	41			6 426	10	42					
			6 854	19	49			7 283	19	49			7 711	18	49			8 568	18	49					
			8 568	29	55			9 104	29	55			9 639	28	55			10 710	28	55					
			3 917	5	31			4 162	5	32			4 406	4	31			4 896	4	32					
			5 875	10	42			6 242	10	42			6 610	10	42			7 344	10	42					
			7 834	19	49			8 323	19	50			8 813	18	49			9 792	18	50					
			9 792	29	55			10 404	29	55			11 016	28	55			12 240	28	56					
			4 406	5	32			4 682	4	32			4 957	4	31			5 508	4	32					
			6 610	10	42			7 023	10	42			7 436	10	42			8 262	10	42					
			8 813	19	50			9 364	18	50			9 914	17	50			11 016	17	50					
			11 016	29	56			11 705	28	56			12 393	27	55			13 770	27	56					
			4 896	5	32			5 202	4	32			5 508	4	32			6 120	4	32					
			7 344	10	43			7 803	10	43			8 262	10	42			9 180	10	43					
			9 792	19	50			10 404	18	50			11 016	17	50			12 240	17	50					
			12 240	29	56			13 005	28	56			13 770	27	56			15 300	27	56					
			5 386	5	33			5 722	4	33			6 059	4	32			6 732	4	33					
			8 078	10	43			8 583	10	43			9 088	10	43			10 098	10	43					
			10 771	19	51			11 444	18	51			12 118	17	50			13 464	17	51					
			13 464	29	57			14 306	28	56			15 147	27	56			16 830	27	57					
			5 875	5	33			6 242	4	33			6 610	4	33			7 344	4	33					
			8 813	10	44			9 364	10	43			9 914	10	43			11 016	10	44					
			11 750	19	51			12 485	18	51			13 219	17	51			14 688	17	51					
			14 688	29	57			15 606	28	57			16 524	27	57			18 360	27	57					
			6 365	5	33			6 763	4	33			7 160	4	33			7 956	4	34					
			9 547	10	44			10 144	10	44			10 741	10	44			11 934	10	44					
			12 730	19	52			13 525	18	51			14 321	17	51			15 912	17	52					
			15 912	29	57			16 907	28	57			17 901	27	57			19 890	27	57					
			6 854	4	33			7 283	4	33			7 711	4	33			8 568	4	33					
			10 282	10	44			10 924	10	44			11 567	9	43			12 852	9	44					
			13 709	18	51			14 566	17	51			15 422	17	51			17 136	17	51					
			17 136	28	57			18 207	27	57			19 278	26	57			21 420	26	57					
			7 344	4	34			7 803	4	33			8 262	4	33			9 180	4	34					
			11 016	10	44			11 705	10	44			12 393	9	44			13 770	9	44					
			14 688	18	52			15 606	17	51			16 524	17	51			18 360	17	52					
			18 360	28	57			19 508	27	57			20 655	26	57			22 950	26	57					
			7 834	4	34			8 323	4	34			8 813	4	33			9 792	4	34					
			11 750	10	44			12 485	10	44			13 219	9	44			14 688	9	44					
			15 667	18	52			16 646	17	52			17 626	17	52			19 584	17	52					
			19 584	28	58			20 808	27	58			22 032	26	57			24 480	26	58					
			8 323	4	34			8 843	4	33			9 364	4	34			10 404	4	34					
			12 485	10	44			13 265	9	44			14 045	9	44			15 606	9	45					
			16 646	17	52			17 687	17	52			18 727	17	52			20 808	17	52					
			20 808	27	58			22 109	26	57			23 409	26	58			26 010	26	58					
			8 813	4	34			9 364	4	34			9 914	4	34			11 016	4	34					
			13 219	10	45			14 045	9	44			14 872	9	45			16 524	9	44					
			17 626	17	52			18 727	17	52			19 829	17	52			22 032	16	52					
			22 032	27	58			23 409	26	58			24 786	26	58			27 540	25	58					
			9 792	4	34			10 404	4	34			11 016	4	33			12 240	4	34					
			14 688	9	44			15 606	9	44			16 524	9	44			18 360	9	44					
			19 584	17	52			20 808	16	52			22 032	15	51			24 480	15	52					
			24 480	26	58			26 010	25	58			27 540	24	57			30 600	24	58					

7. Estimated Weights of WIP/V, WIP/V-M dampers [kg]

		width B [mm]									
		200	250	300	400	500	600	700	800	900	1000
height H [mm]	200	10	10	10	10	15	17	18	19	22	25
	250	10	10	11	11	16	18	18	21	24	27
	300	10	11	11	12	17	20	21	23	26	28
	350	11	11	11	16	18	21	23	26	28	30
	400	12	12	14	18	19	21	25	29	30	33
	500	15	16	17	19	20	23	27	32	33	35
	600	17	18	20	21	23	26	30	35	37	39
	700	18	18	21	23	25	28	32	35	38	40
	800	20	21	22	24	29	35	37	41	43	49
	900	22	25	25	28	33	35	39	43	49	52
	1000	23	29	32	33	36	42	43	47	53	60

8. Marking

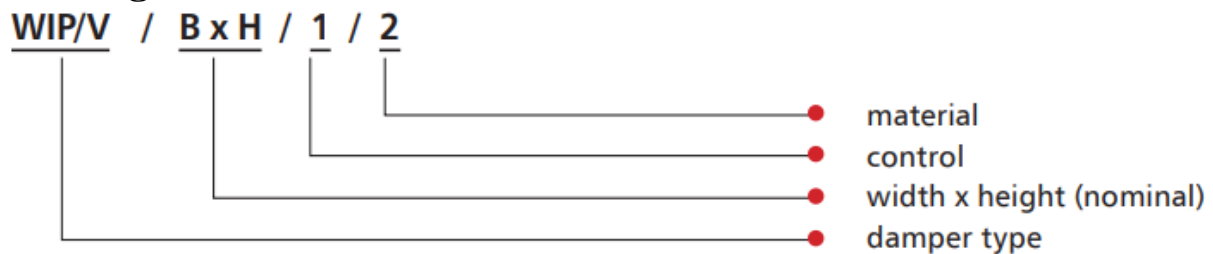

1 – Control:

- Belimo trigger control mechanism

BE24 – actuator with no return spring, U = 24 V AC/DC

BE24-ST (with the BKNE230-24 option) – actuator with no return spring, U = 24 V AC/DC, with a SBS Control system

BE230 – actuator with no return spring, U = 230 V AC/DC

BLE24 – actuator with no return spring, U = 24 V AC/DC

BLE24-ST (with the BKNE230-24 option) – actuator with no return spring, U = 24 V AC/DC, with a SBS Control system

BLE230 – actuator with no return spring, U = 230 V AC/DC

2 – Material:

[No symbol] – galvanized steel, Zn 275 g/m² coating

KN – 1.4404 acid-proof stainless steel

Example marking:

WIP/V 400 x 400 BLE24

Louvered fire damper with a compact 24 V Belimo actuator with limit switches.

9. Power Supply Control

9.1 Cooperation with smoke exhaust/cut-off dampers – drive quick selection table

	FID S/S c/P	FID S/S p/P FID S/S p/O	FID S/V p/P FID S/V-M p/P	FID PRO	WIP/ S	WIP/T	WIP/T- G	WIP/V WIP/V-M	WIP PRO/S	WIP PRO/V WIP PRO/V- M
BF24-T (ST)		X			X	X			X	
BF230-T		X			X	X			X	
BFL24-T (-ST)	X	X		X	X	X			X	
BFL230-T	X	X		X	X	X			X	
BFN24-T (-ST)	X	X			X	X			X	
BFN230-T	X	X			X	X			X	
BE24			X			X		X		X
BE230			X			X		X		X
BLE24			X			X		X		X
BLE230			X			X		X		X
EXBF24-T	X	X		X	X	X			X	
EXBF230-T	X	X		X	X	X			X	
BF24TL-T (-ST)	X	X		X	X	X			X	
RST	X	X		X						
RST/WK1	X	X		X						
RST/WK2	X	X		X						
RST-KW1/S	X	X		X						
RST-KW1/S/WK2	X	X		X	X	X	X		X	
RST-KW1/24I	X	X		X						
RST-KW1/24P	X	X		X					X	
RST-KW1/230I	X	X		X						
RST-KW1/230P	X	X		X					X	
BF24 (-ST)							X			
BF230							X			
BFL24 (-ST)							X			
BFL230							X			
BFN24 (-ST)							X			
BFN230							X			

9.2 Actuators

9.2.1 BF electric actuators

SPECIFIKATIONS	BF24 (BF24-T)	BF230 (BF230-T)
Power supply	AC 24 V 50/60 Hz DC 24 V	AC 220-240 V 50/60 Hz
Power demand:		
- For spring tensioning	7 W	8 W
- For holding	2 W	3 W
Sizing (apparent power)	10 VA	11 VA
Protection class	III	II
Ingress protection rating	IP 54	IP 54
Auxiliary circuit breaker:	2 x EPU 3 (0.5) A 250 V	2 x EPU 3 (0.5) A 250 V~
- Activation position	5°, 80°	5°, 80°
Torque		
- Motor	18 Nm	18 Nm
- Return spring	12 Nm	12 Nm
Cable connection:		
- Motor (length: 0.9 m)	2 x 0.75 mm ²	2 x 0.75 mm ²
- Auxiliary circuit breaker	6 x 0.75 mm ²	2 x 0.75 mm ²
Movement time (0-90°)		
- Motor	120 s	120 s
- Return spring	~16 s	~16 s
Operating temperature range	-30...+50°C	-30...+50°C
Sound intensity level:		
- Motor	max 45 dB (A)	max 45 dB (A)
- Return spring	~63 dB (A)	~63 dB (A)

9.2.1.1 Electrical diagram of the BF...-T series actuator:

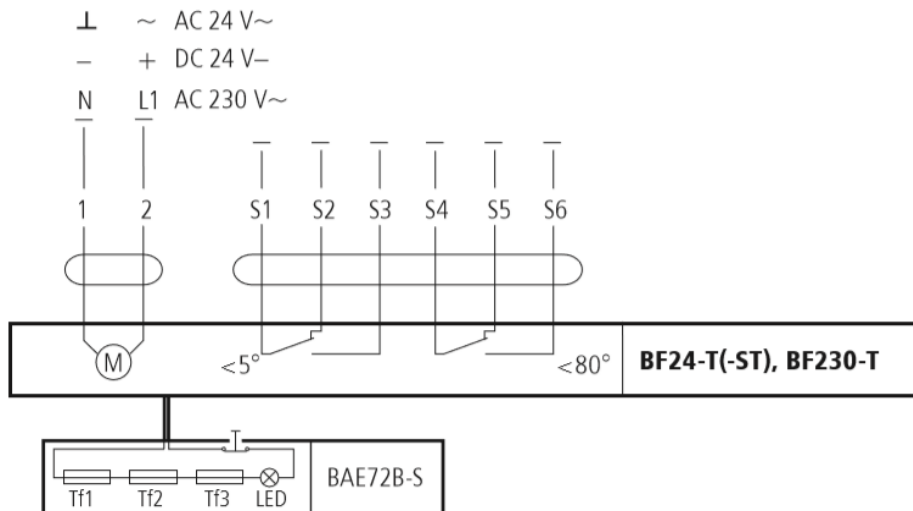

note: 24 V connection through a safety transformer.

To disconnect the 230 V actuator from the mains, the gap of at least 3 mm between the contacts (when off) is required in the switch. It is possible to connect further actuators in parallel. Check the power consumption.

note:

The location of the actuator limit switches is shown for the no voltage position.

9.2.1.2 Electrical diagram of the BF24TL-T(-ST) and BF24TL(-ST) actuator:

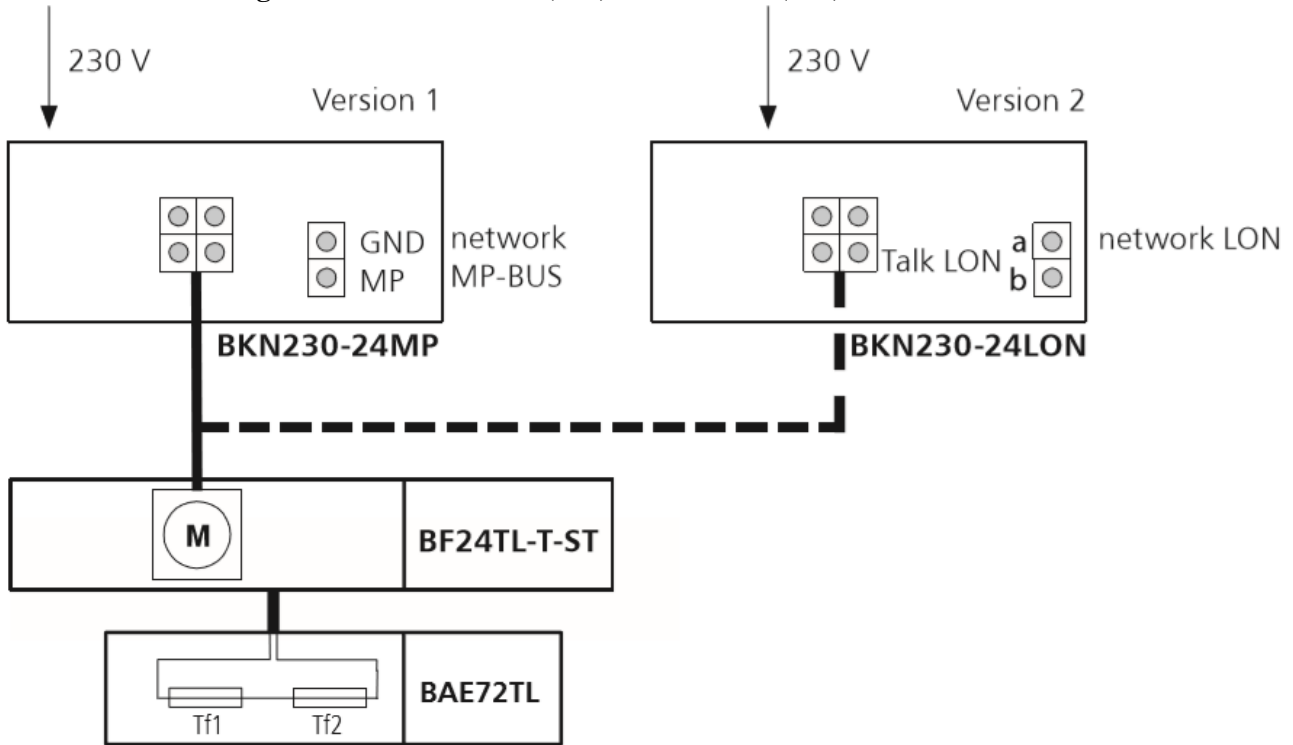

9.2.1.3 Electrical Diagram of the BF series actuator:

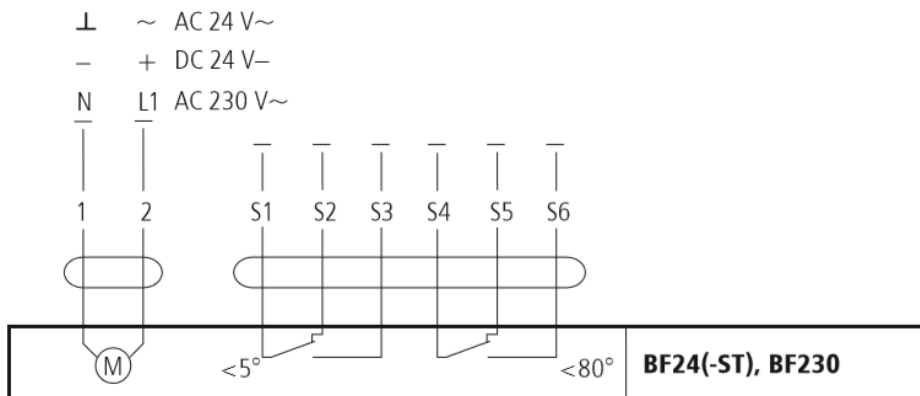

note: 24 V connection through a safety transformer. To disconnect the 230 V actuator from the mains, the gap of at least 3 mm between the contacts (when off) is required in the switch. It is possible to connect further actuators in parallel. Check the power consumption.

note: The location of the actuator limit switches is shown for the no voltage position.

9.2.2 BE, BLE electric actuators

Specifications	BE24, BE24-ST	BE230	BLE24	BLE230
Power Supply	AC 24 V 50/60 Hz	AC 230 V 50/60 Hz	AC 24 V 50/60 Hz DC 24 V	AC 230 V 50/60 Hz
Power demand:				
- In movement	12 W	8 W	7.5 W	5 W
- For holding	0.5 W	0.5 W	0.5 W	0.5
Sizing (apparent power)	18 VA	15 VA	9 VA	12 VA
Protection class	III	II	III	II
Ingress protection rating	IP 54	IP 54	IP 54	IP 54
Auxiliary circuit breaker:	2 x SPDT 6 (1.5) A AC 250 V	2 x SPDT 6 (1.5) A AC 250 V	2 x EPU 3 (1.5) A 250 V	2 x EPU 3 (1.5) A 250 V~
- Activation position	5°, 80°	5°, 80°	5°, 80°	5°, 80°
Torque - motor	40 Nm	40 Nm	15 Nm	15 Nm
Movement time (0-90°) – motor	< 60 s for 90°	< 60 s for 90°	< 30 s for 90°	< 30 s for 90°
Operating temperature	-30...+50°C	-30...+50°C	-30...+50°C	-30...+50°C
Sound intensity level	~62 dB (A)	~62 dB (A)	~62 dB (A)	~62 dB (A)

9.2.2.1 Electric diagram of the BE, BLE series actuator

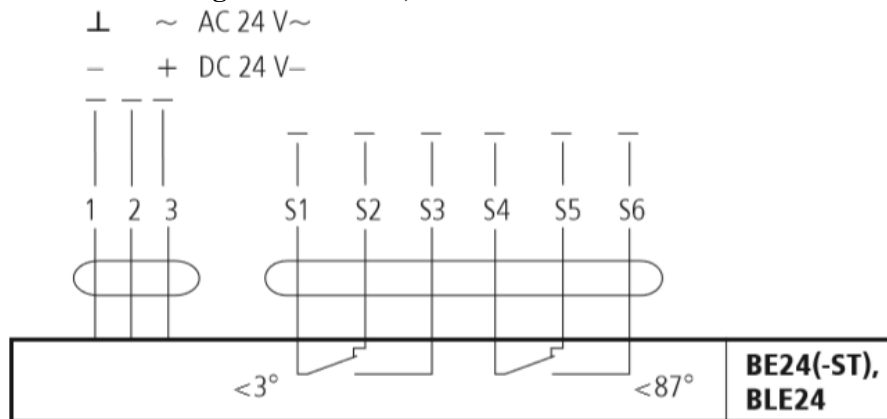

note:

The actuator operation control requires routing three wire system to it. The actuator rotation sense is changed by the application of the power supply voltage to the terminal 2 or 3, depending on the desired direction.

note: 24 V connection through a safety transformer.

To disconnect the 230 V actuator from the mains, the gap of at least 3 mm between the contacts (when off) is required in the switch. It is possible to connect further drives in parallel. Check the power consumption.

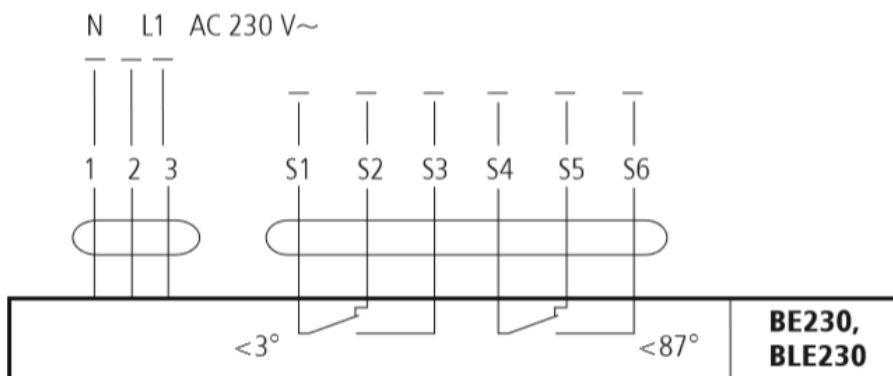

note:

The location of the actuator limit switches is shown for the no voltage position.

9.2.3 BFL, BFN ELECTRIC ACTUATORS

Specifications	BFL24 (BFL24-T)	BFL230 (BFL230-T)	BFN24 (BFN24-T)	BFN230 (BFN230-T)
Power Supply	AC 24 V 50/60 Hz DC 24 V	AC 220-240 V 50/60 Hz	AC 24 V 50/60 Hz DC 24 V	AC 220-240 V 50/60 Hz
Power demand:				
- Spring tensioning	2.5 W	3.5 W	4 W	5 W
- For holding	0.7 W	1.1 W	1.4 W	2.1
Sizing (apparent power)	4 VA	6.5 VA	6 VA	10 VA
Protection class	III	II	III	II
Ingress protection rating	IP 54	IP 54	IP 54	IP 54
Auxiliary circuit breaker:	2 x SPDT 3 (0.5) A AC 250 V	2 x SPDT 3 (0.5) A AC 250 V	2 x EPU 3 (0.5) A 250 V	2 x EPU 3 (0.5) A 250 V
- Activation position	5°, 80°	5°, 80°	5°, 80°	5°, 80°
Torque				
- motor	4 Nm	4 Nm	9 Nm	9 Nm
- return spring	3 Nm	3 Nm	7 Nm	7 Nm
Movement time (0-90°):				
- motor	< 60 s	< 60 s	< 60 s	< 60 s
- return spring	~20 s	~20 s	~20 s	~20 s
Operating temperature	-30...+55°C	-30...+55°C	-30...+55°C	-30...+55°C
Sound intensity level				
- motor	max 43 dB (A)	max 43 dB (A)	max 55 dB (A)	max 55 dB (A)
- return spring	~62 dB (A)	~62 dB (A)	~67 dB (A)	~67 dB (A)

9.2.3.1 Electrical diagram of the BFL...-T, BFN...-T series actuator:

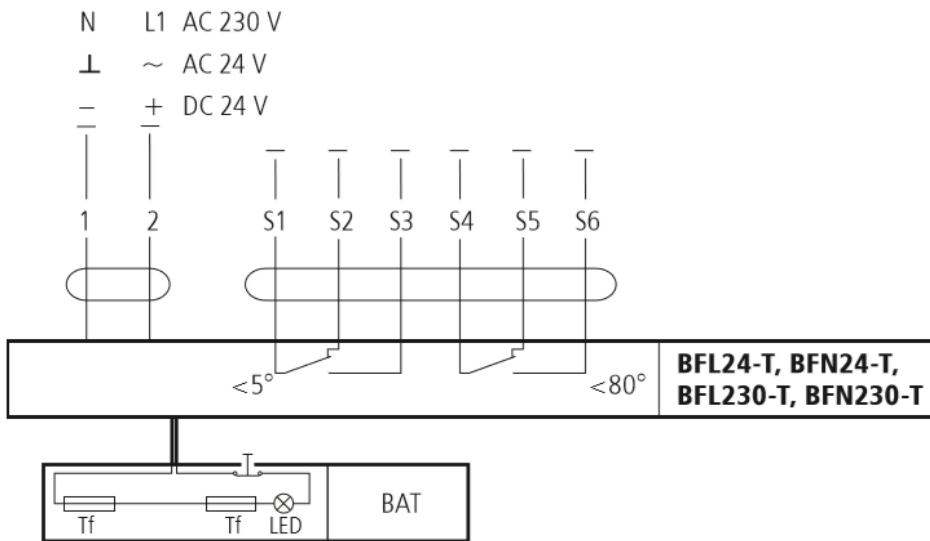

note: 24 V connection through a safety transformer. To disconnect the 230 V actuator from the mains, the gap of at least 3 mm between the contacts (when off) is required in the switch. It is possible to connect further actuators in parallel. Check the power consumption.

note: The location of the actuator limit switches is shown for the no voltage position.

9.2.3.2 Electrical diagram of the BFL, BFN series actuator:

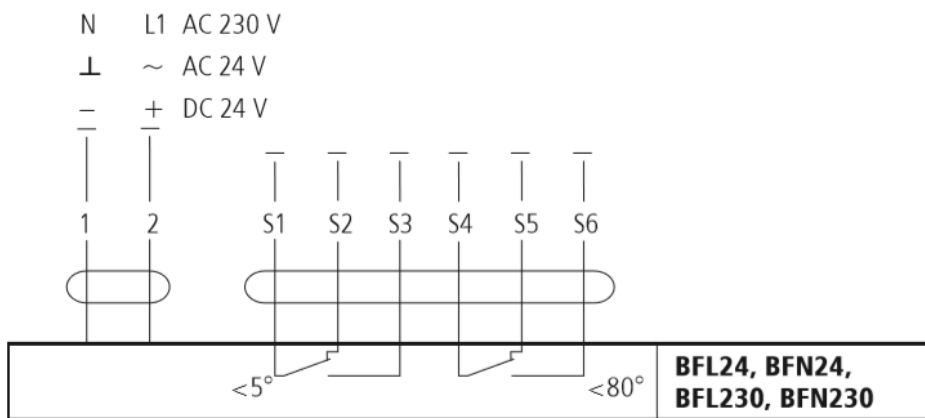

note: 24 V connection through a safety transformer.

To disconnect the 230 V actuator from the mains, the gap of at least 3 mm between the contacts (when off) is required in the switch. It is possible to connect further actuators in parallel. Check the power consumption.

note:

The location of the actuator limit switches is shown for the no voltage position.

9.2.4 EXBF actuators

SPECIFIKATIONS	EXBF B 001 2...0 N 000	EXBF A 001 2 ...0 N 000
Zone	1, 2, 21, 22	
ATEX-rating	II 2 GD EEx d IIC T6	
Power supply	24 V AC $\pm 20\%$ 50/60 Hz / 24 V DC - 10/+20%	230 V AC $\pm 14\%$ 50/60 Hz
Power demand:		
- For spring tensioning	7 W	8 W
- For holding	2 W	3 W
Sizing (apparent power)	10 VA	11 VA
Ingress protection rating	IP 66	IP 66
Auxiliary circuit breaker:	2 x SPDT 6 A (3) max 250 v AC	2 x SPDT 6 A (3) max 250 V AC
- Activation position	5°, 80°	5°, 80°
Torque:		
- Motor	18 Nm	18 Nm
- Return spring	12 Nm	12 Nm
Movement time (0-90°)		
- Motor	150 s	150 s
- Return spring	~20 s	~20 s
Ambient temperature	-30...+50°C	-30...+50°C

9.2.4.1 Connection diagram for EXBF and EXBF...-T actuators:

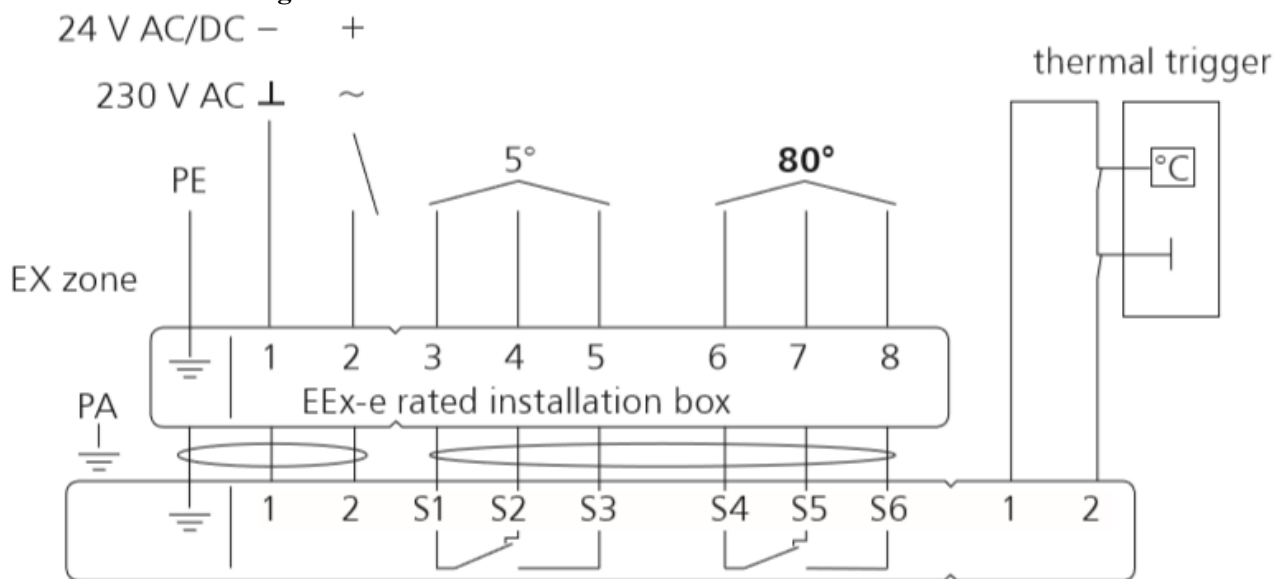

9.3 RST trigger control mechanisms

In the RST version the WK1 limit switches are independent units installed inside the fire damper casing. The thermal trigger is on the damper blade. The driving spring is installed on the damper blade or in a guard box on its casing.

1. Moving hook with nut
2. Fusible link
3. Fixed hook on the damper blade
4. Damper blade
5. Drive spring

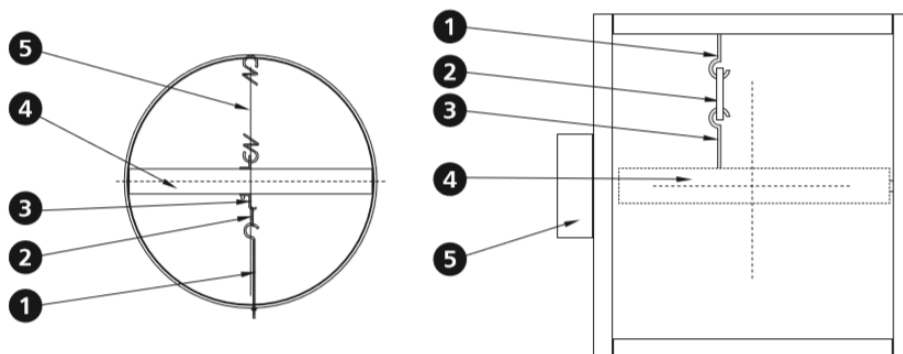

9.3.1 Independent limit switches – RST version

WK1 – limit switch (closed damper blade signal)

WK2 – limit switch (closed/open damper blade signal)

9.3.2 Switch specifications

WK1 and WK2 limit switch	1xNO/1xNC SPDT 5 A, 230 V AC
Limit switch operating temperature	-25 ... +85°C
Casing	plastic

9.3.2.1 Electric connection diagram of WK1 and WK2 limit switches

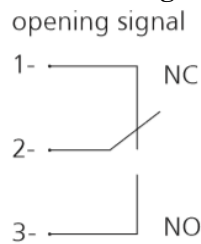

note:

When the damper blade closes, the closed indication limit switch is switched over (contacts 2-3 are closed).

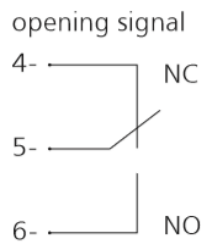

9.4 RST-KW1 mechanisms

	RST-KW1/S	RST-KW1/S/WK2	RST-KW1/24I	RST-KW1/24P	RST-KW1/230I	RST-KW1/230P
Rated voltage	-	-	24 V – 48 V DC	24 V – 48 V DC	230 AC	230 AC
Power consumption	-	-	3.5 W	1.6 W	2 W	2 W
Thermal trigger	74°C (optionally 95°C)					
Connections – trigger	-	-	Wire 0.6m, 2 x 0.5 mm ²			
Connections – limit switches	-	-	Wire 0.6m, 6 x 0.5 mm ²			
Limit switch	-	-	2 x BI/NC 5A. 230 V AC			
Movement time	max. 2 s					
Mechanism operation control (closing)	-	-	Voltage application „pulse”	Voltage removal „break”	Voltage application „pulse”	Voltage removal „break”
Mechanism operation control (opening)	Manual	Manual	Manual	Manual	Manual	Manual
Pulse width	max. 1 s					

9.4.1 Description of electrical connections:

RST-KW1 mechanism power supply	Closing limit switch	Opening limit switch
Wire number: 1-2	Wire number: 3-4 – NO (normally open)	Wire number 6-7 – NO (normally open)
	Wire number 4-5 – NC (normally closed)	Wire number 7-8 – NC (normally closed)

9.5 Manufacture standards

Damper type	Description	Standard	Option
FID S/S c/P	Right damper	X	
	Inverse damper		X
	Left damper		X
	Actuator normal to the axis flow	X	
	Actuator along the axis flow		
FID S/S p/P FID S/V p/P	Right damper	X	
	Inverse damper		X
	Left damper		X
	Actuator normal to the axis flow	X	
	Actuator along the axis flow		X
FID S/S p/O	Right damper	X	
	Inverse damper		
	Left damper		
	Actuator normal to the axis flow	X	
	BF actuator along the v (exception)	X	
	Actuator along the axis flow		X
FID PRO	Right damper	X	
	Inverse damper		
	Left damper		
	Actuator normal to the axis flow	X	
	Actuator along the axis flow		X
WIP	Right damper		
	Inverse damper		X
	Left damper		X
	Actuator normal to the axis flow	X	
	Actuator along the axis flow	X	
WIP PRO	Right damper		X
	Inverse damper		X
	Left damper	X	
	Actuator normal to the axis flow	X	
	Actuator along the axis flow		

9.5.1 FID S/S c/P damper

right damper standard

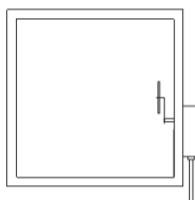
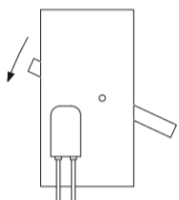

inverse damper
(wires downward)

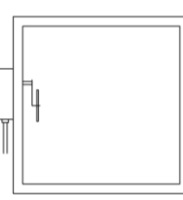
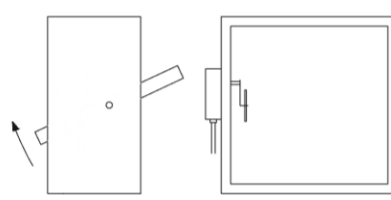

left damper

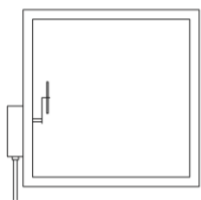
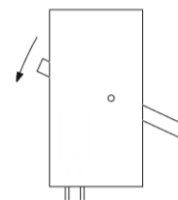

9.5.2 FID S/S p/P, FID S/S p/O, FID S/V p/P damper

right damper standard

inverse damper
(wires downward)

left damper

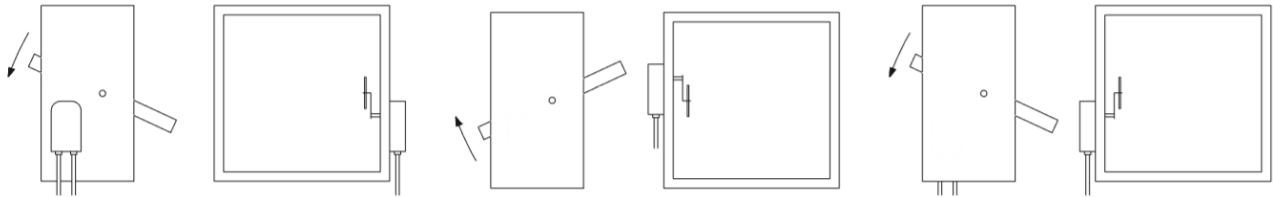

9.5.3 FID PRO/S damper

right damper
standard

actuator along the axis flow

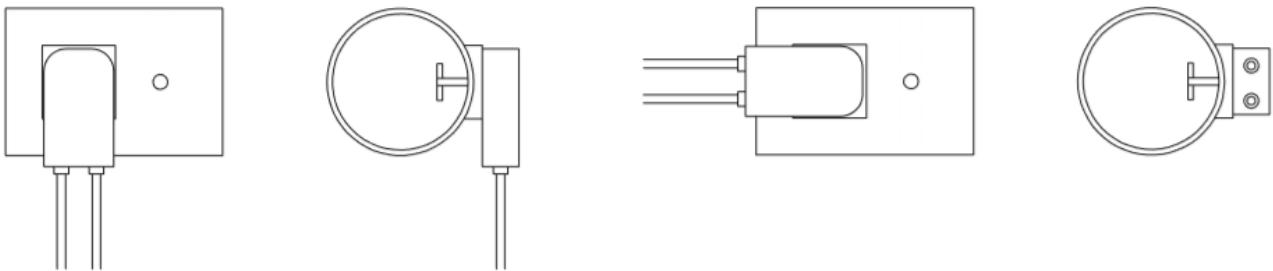

9.5.4 WIP/S, WIP/V, WIP/V-M, WIP/T, WIP/T-G damper

left damper
standard

inverse damper
(wires downward)



9.5.5 WIP PRO/S, WIP PRO/V, WIP PRO/V-M damper with an actuator

left damper
standard

inverse damper
reversed cable outlet

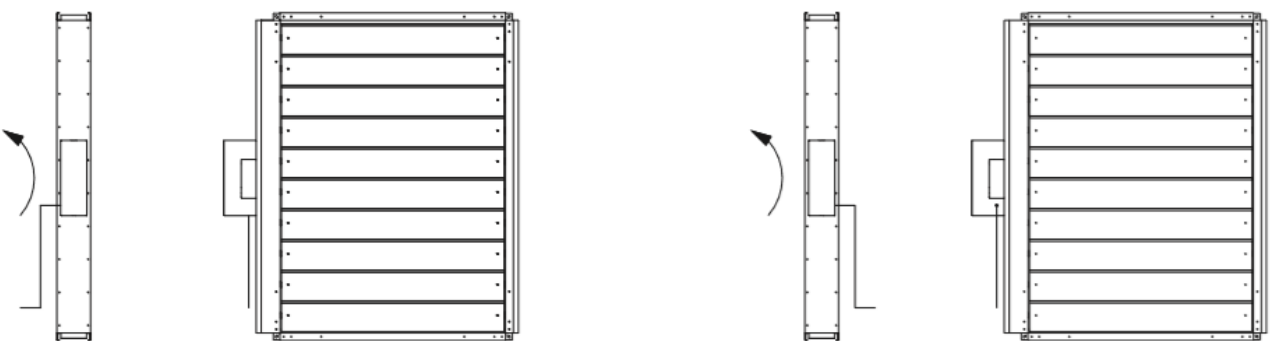

i Installation in reversed horizontal and vertical position available

9.5.6 WIP PRO/S, WIP PRO/V, VIP PRO/V-M damper with RST-KW1 mechanism

left damper
standard

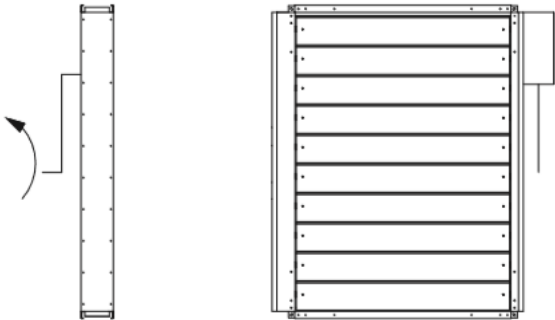

inverse damper
reversed cable outlet

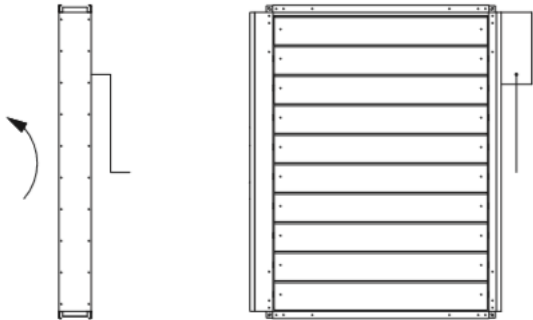

i Installation in reversed horizontal and vertical position available